

NCEA



**LEVEL 1
MATHEMATICS**

**Part 2 - AS90148
Sketch and Interpret Graphs**

QUESTIONS & ANSWERS



*Published by Mahobe Resources (NZ) Ltd
Distributed free at www.mathscentre.co.nz*

NCEA Level 1 Mathematics, Questions & Answers
Part 2 - AS90148 Sketch and Interpret Graphs

Contributors: Paula Campbell, Dr Chris Davidson, Kim Freeman, Farisha Khan, Ria Nu'u, Andy Peterson.

This edition is Part 2 of a 6 Part eBook series designed to help you study towards NCEA.

Published in 2009 by:

Mahobe Resources (NZ) Ltd
P.O. Box 109-760
Newmarket, Auckland
New Zealand

www.mahobe.co.nz
www.mathscentre.co.nz

© Mahobe Resources (NZ) Ltd
ISBN(13) 9781877489075



This eBook has been provided by Mahobe Resources (NZ) Ltd to *The New Zealand Centre of Mathematics*. School teachers, University lecturers, and their students are able to freely download this book from *The New Zealand Centre of Mathematics* website www.mathscentre.co.nz. Electronic copies of the complete eBook may not be copied or distributed. Students have permission to print one copy for their personal use. Any photocopying by teachers must be for training or educational purposes and must be recorded and carried out in accordance with Copyright Licensing Ltd guidelines. The content presented within the book represents the views of the publisher and his contributors as at the date of publication. Because of the rate with which conditions change, the publisher and his contributors reserve the right to alter and update the contents of the book at any time based on the new conditions. This eBook is for informational purposes only and the publisher and his contributors do not accept any responsibilities for any liabilities resulting from the use of the information within. While every attempt has been made to verify the content provided, neither the publisher nor his contributors and partners assume any responsibility for errors, inaccuracies or omissions. All rights reserved. All the views expressed in this book are those of the author. The questions and suggested answers are the responsibility of the contributors and have not been moderated for use in NCEA examinations.

Contents



About this Book	5
Straight Line Graphs	8
Graphs - Achievement Example	10
Merit Example - Straight Line Graphs	21
Quadratic Graphs	22
Drawing a Parabola from Factorised Quadratics	23
Transforming Quadratic Graphs	24
Quadratic Graphs - Merit Example	29
Finding the Equation of a Parabola	38
Quadratic Graphs - Excellence Example	40
Sample Exam Paper	46
The Answers	55



About This Book

Q&A eResources are recognised as the leading study guides for NCEA. Each freely available title has been compiled by a team of experienced educators to meet the study and revision needs of NCEA students. They are proving to be valuable resources in the hands of students who want to work ahead of their regular class programme. They also serve as effective revision programmes in the run up to the final examinations.

This book carefully explains the mathematical concepts that will be tested in NCEA then illustrates them with Achievement, Merit and Excellence exemplars. It allows students to practise on NCEA-type questions and provides detailed solutions. After working through this programme, all students will be well prepared for their final assessments.

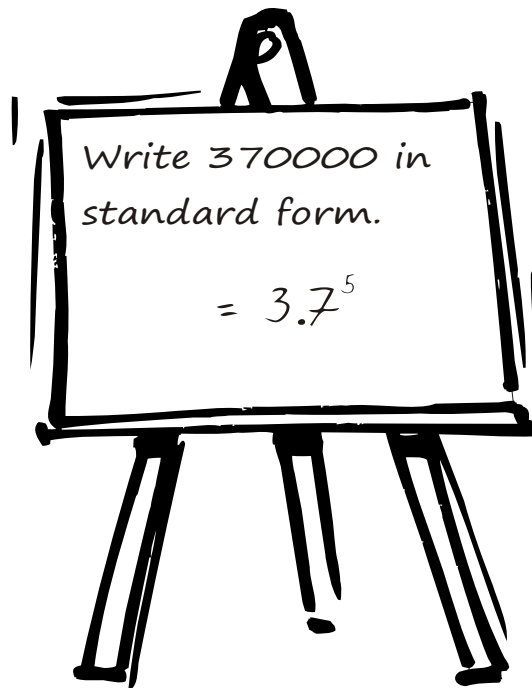

The student who wrote the above answer on a recent assessment paper did not use a Q&A Level 1 Mathematics eResource.

MATHEMATICS 1.2 - AS90148

Sketch and interpret graphs

Always understand what the examiner wants! A past examination answer is shown below. The student who wrote this answer on a recent assessment paper did not use a Q&A Level 1 Mathematics eResource.

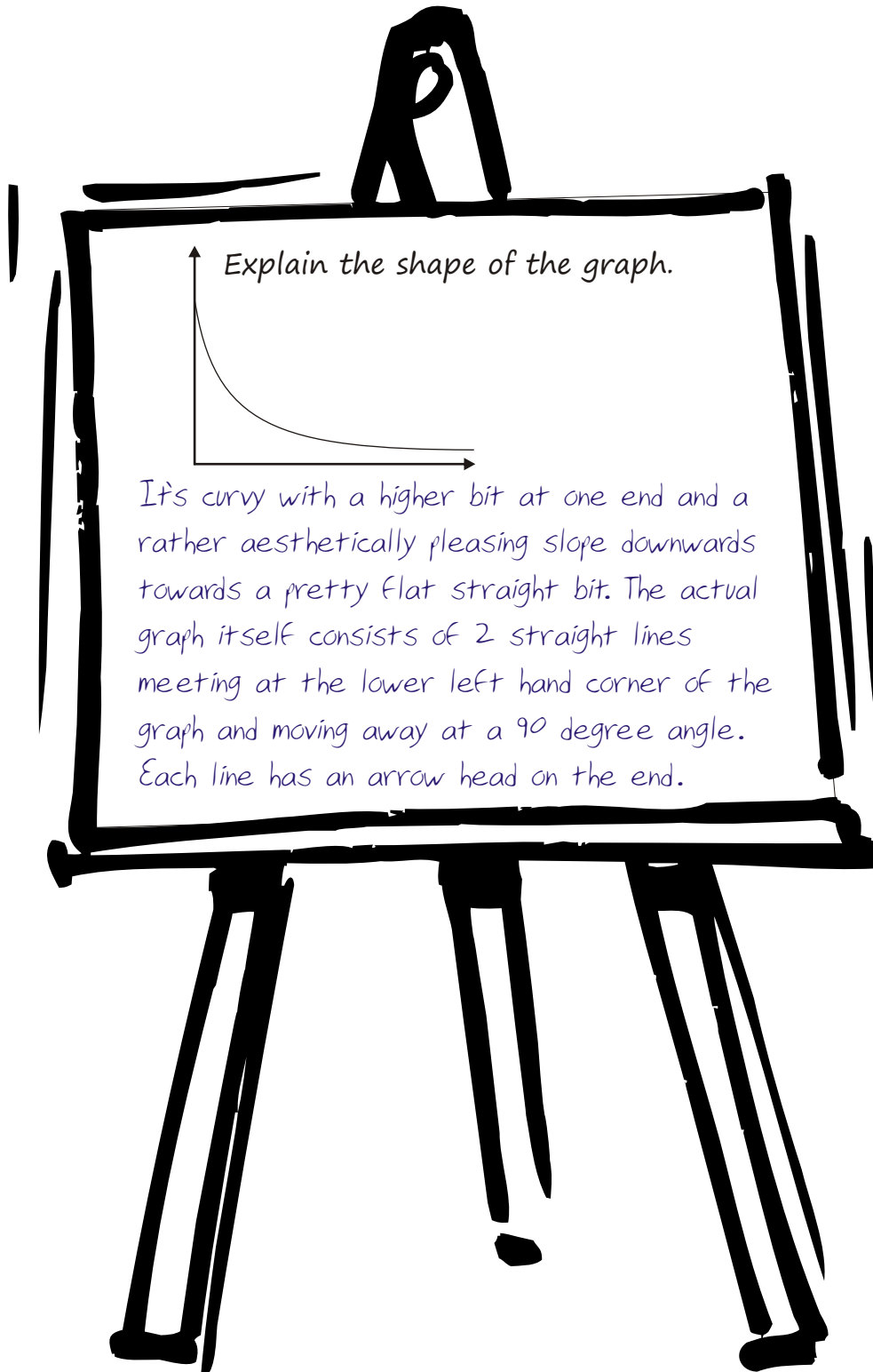

Straight Line Graphs

Straight line graphs are also called 'linear graphs'. A common equation that produces a straight line is $y = mx + c$ where m is the gradient (slope) of the line and c is the point where it intercepts the y axis.

Features of a Graph

Here are some values for x and y . Plot the values then list all the features of the graph line produced.

x	-5	-4	-3	-2	-1	0	1	2	3	4	5
y	-5.5	-4	-2.5	-1	0.5	2	3.5	5	6.5	8	9.5

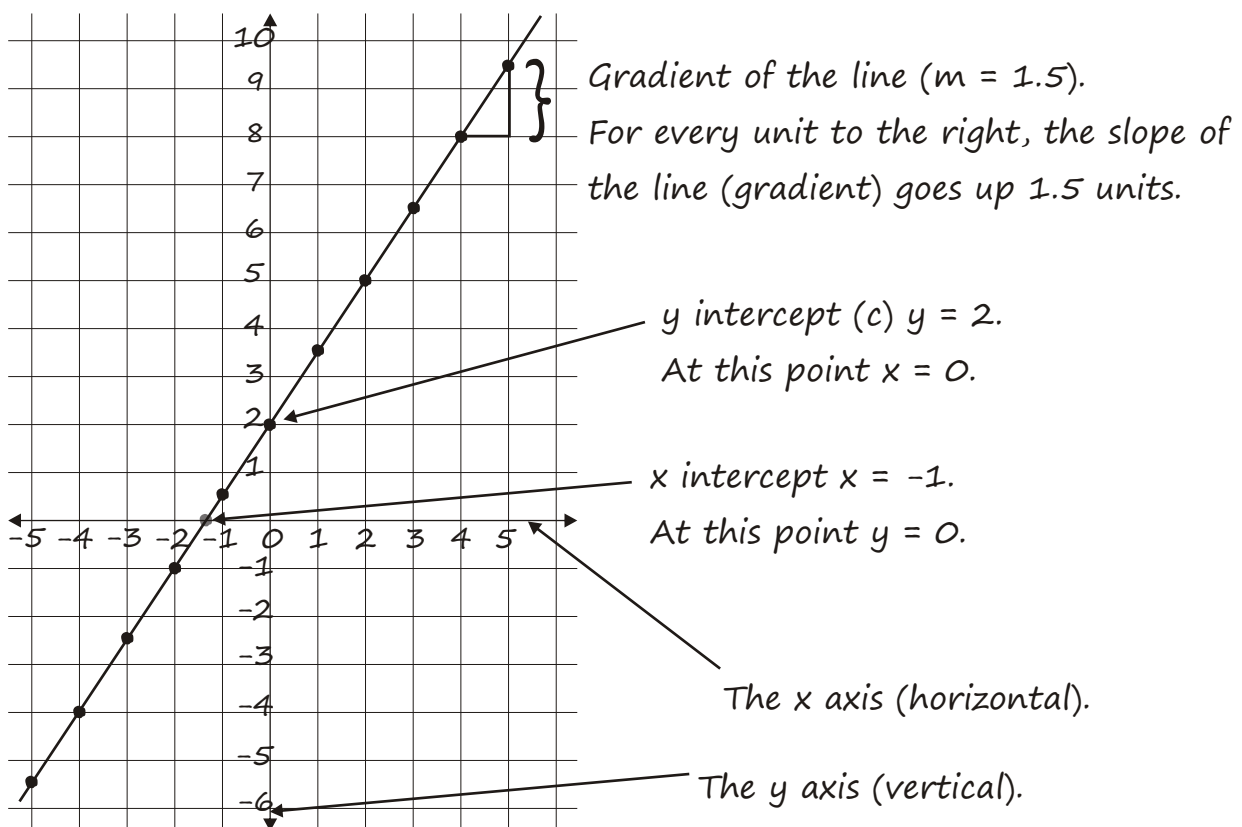

Using the straight line equation ($y = mx + c$), the equation of the line on the graph above is: $y = 1.5x + 2$.

Straight Line Graphs

$$2x - 3y = 12$$

$$y = 2 + 5x$$

$$3y - x - 7 = 0$$

$$5(x + 3y) = 5$$

Not Straight Line Graphs

$$y = x^3 + 4$$

$$x^2 = 4 - y$$

$$xy + 2 = 0$$

$$x(1 - 2y) = 7$$

1. Draw the graphs of the lines $y = \frac{1}{2}x - 3$
 $y = 3x + \frac{1}{2}$

With this type of question you can draw up a table using three or four values of x or you can use the gradient-intercept method ($y = mx + c$).

Table Method

x	0	1	2	4
$y = \frac{1}{2}x - 3$	-3	-2.5	-2	-1

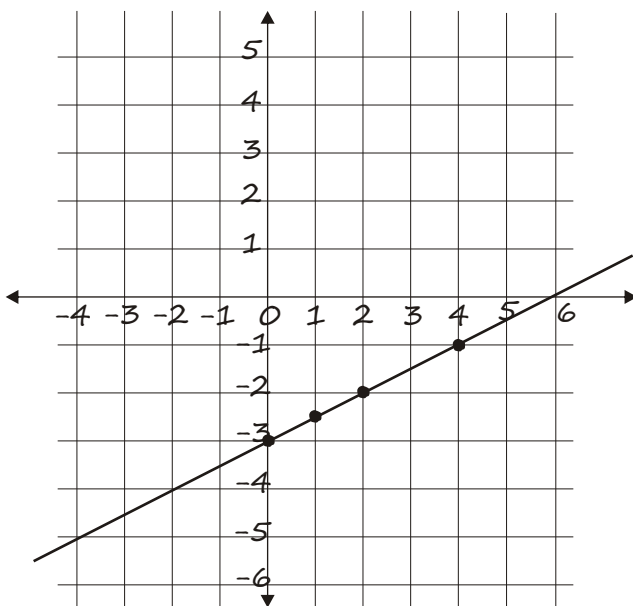

Gradient - Intercept Method

$$y = mx + c$$

$$\gg y = 3x + \frac{1}{2}$$

$$\gg m = 3, c = \frac{1}{2}$$

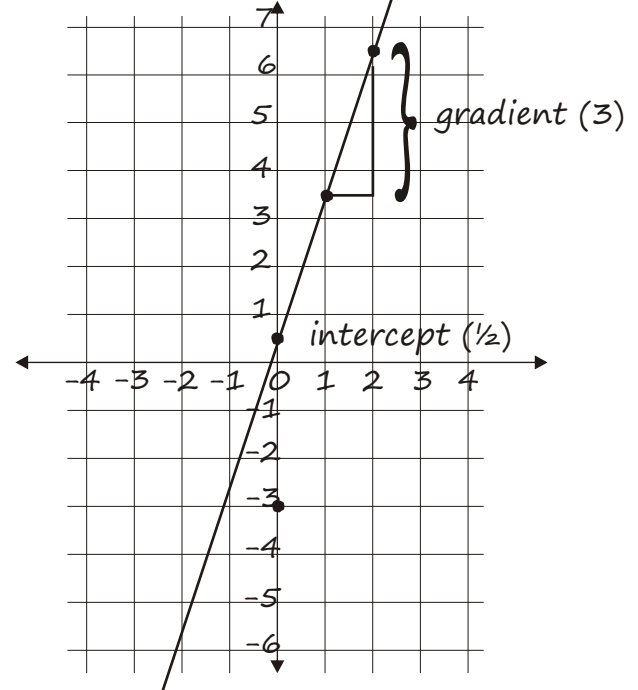

2. Draw the graph of the line: $3x + 5y = 15$

This is still a straight line graph but is not written as $y = mx + c$.

However we can still draw it using the “ $y=0, x=0$ method”.

Putting $x = 0$ gives $5y = 15 \gg y = 3$ i.e. Point $(0, 3)$

Putting $y = 0$ gives $3x = 15 \gg x = 5$ i.e. Point $(5, 0)$

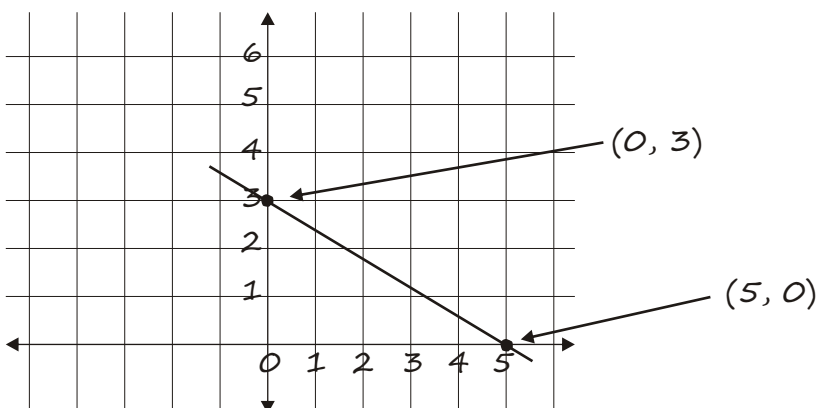

You could still rearrange the equation to: $y = mx + c$

$$3x + 5y = 15$$

$$5y = 15 - 3x$$

$$y = \frac{15}{5} - \frac{3x}{5}$$

$$y = 3 - \frac{3}{5}x$$

$$y = -\frac{3}{5}x + 3$$



Graphs - Achievement Example

Parts of the Red Devils and Easy Riders cycle ramps can be viewed from the end of a spectator stand at a dirt cycle track. The graph below shows the height above ground level of the two ramps.

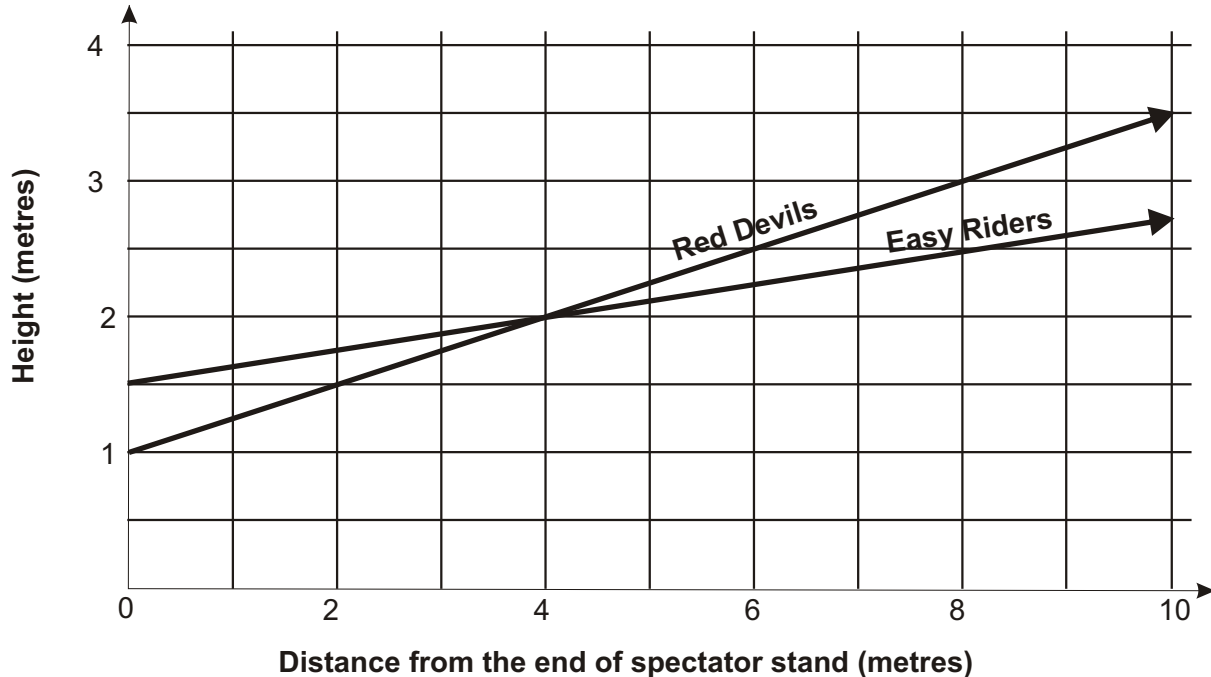

- a. What is the height of the Easy Riders ramp at the end of the spectator stand?

At the end of the spectator stand, distance = 0.

Reading off the y axis at $x = 0$, the height is 1.5 metres

- b. What is the increase in height of the Red Devils ramp over the 10 metres from the end of the spectator stand.

The Red Devils ramp starts at 1.0 m at the end of the spectator stand. It is at a height of 3.5m at 10 metres from the end of the spectator stand.

$$\begin{aligned} \text{Therefore height increase} &= 3.5 - 1 \\ &= 2.5 \text{ metres} \end{aligned}$$

- c. At what distance from the end of the spectator stand are the two ramps the same height?

Both lines meet at 4.0 m from the spectator stand (2.0m high).

Exercises

1. Use the table of values to draw each line onto the axes below.

Mark any points of interest and give the equation of each graph.

a.	x	-5	-4	-3	-2	-1	0	1	2	3	4	5
	y	-20	-17	-14	-11	-8	-5	-2	1	4	7	10

b.	x	-5	-4	-3	-2	-1	0	1	2	3	4	5
	y	21	17	13	9	5	1	-3	-7	-11	-15	-19

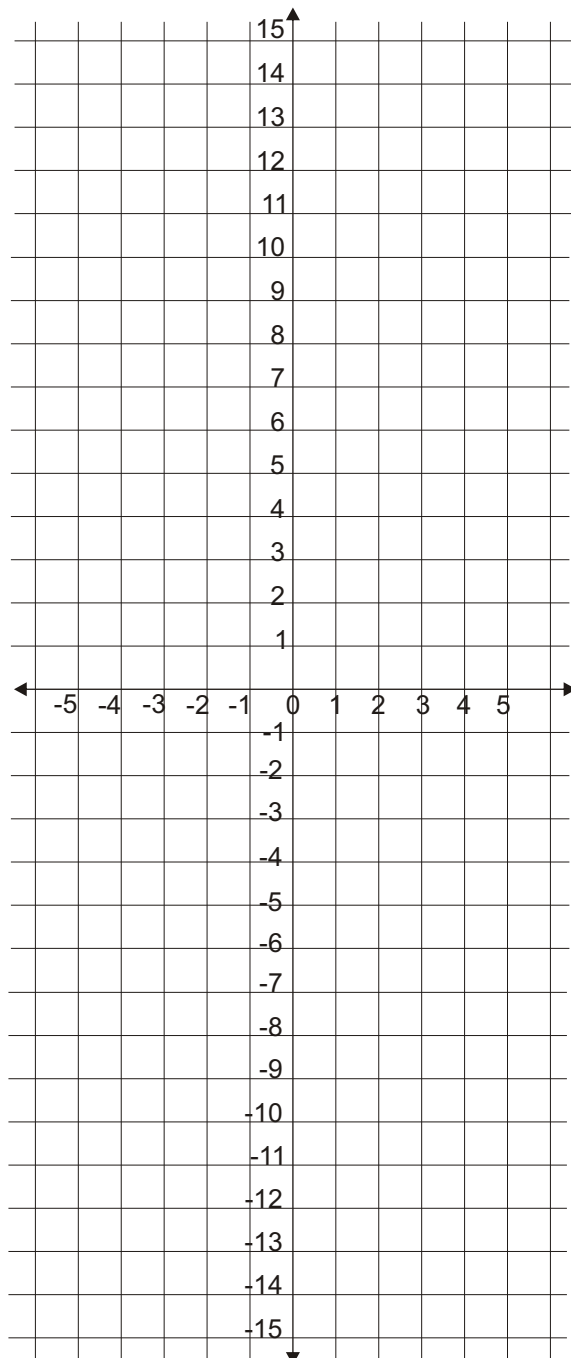

Equation of line a is:

.....

Equation of line b is:

.....



2. Use the linear graph below to answer the questions:

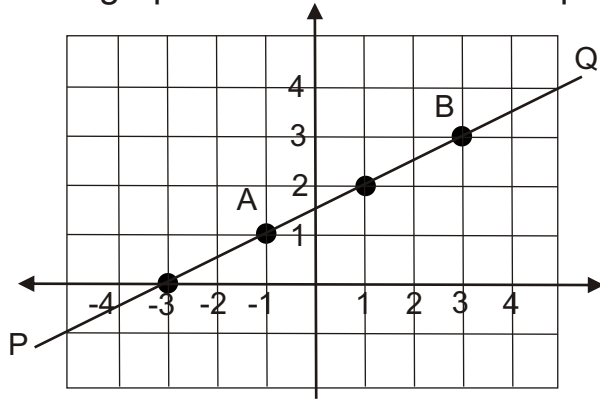

- a. Write down the co-ordinates of A and B.
.....
- b. Write down the x and y intercepts.
.....
- c. Write down the equation of the line PQ.

3. A to D gives 4 different equations:

- A. $y = 3x - 2$
- B. $y = 7 - 2x$
- C. $2y = 6x + 12$
- D. $x + y = 18$

- Which two lines are parallel?
- Which two lines have negative gradients?
- Which two lines go through the point (5, 13)?

4. On the next page are some axes and below a table of values from -3 to 3. For each of the equations either use the table of values or another method to draw each line.

	-3	-2	-1	0	1	2	3
a. $y = 2x - 4$							
b. $y = 3x + 1$							
c. $y = \frac{1}{2}x + 1$							
d. $y = -2x + 8$							

$$y = 2x - 4$$

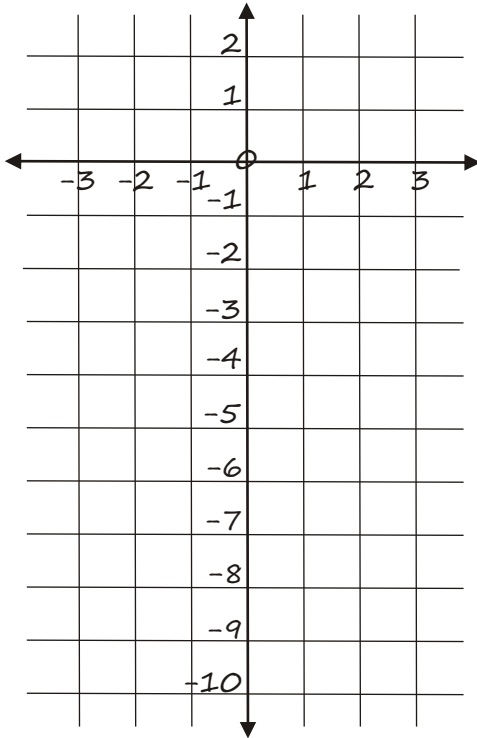

$$y = -2x + 8$$

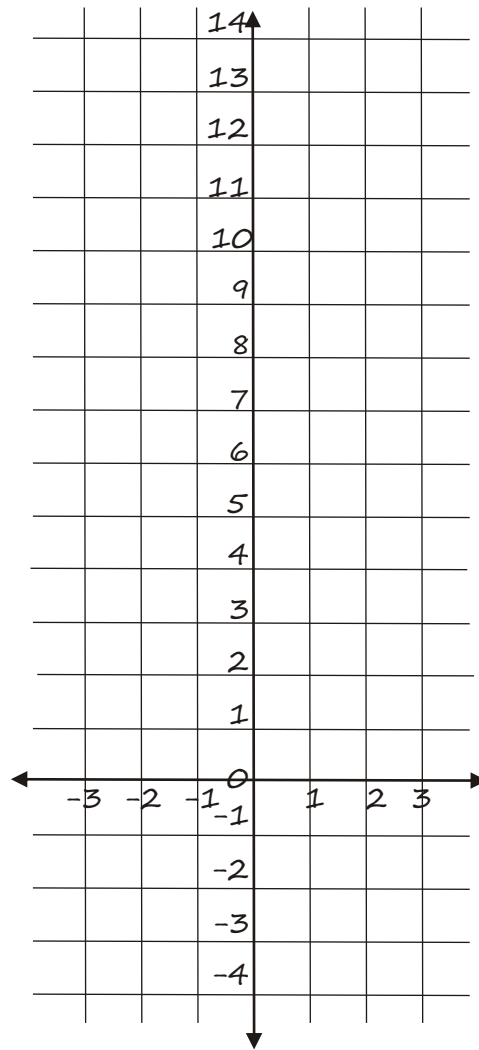

$$y = 3x + 1$$

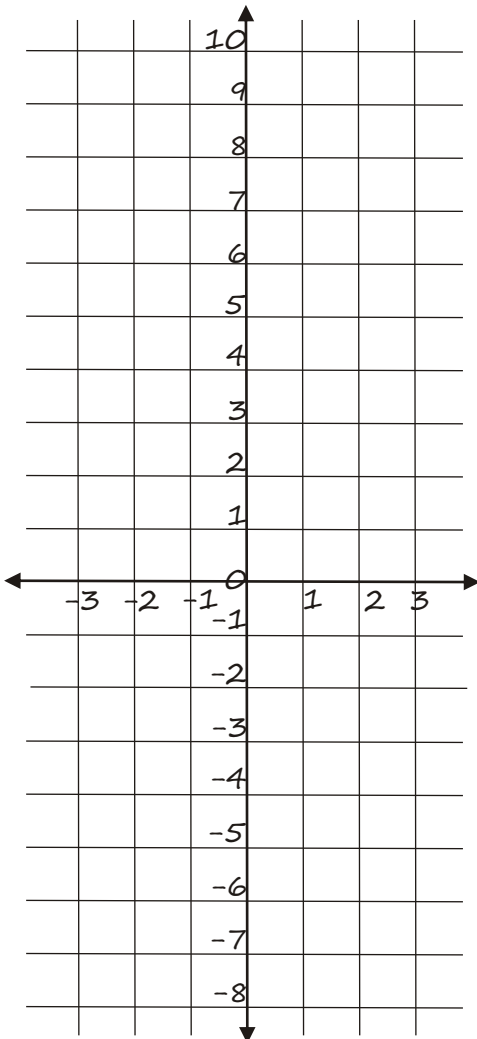

$$y = \frac{1}{2}x + 1$$

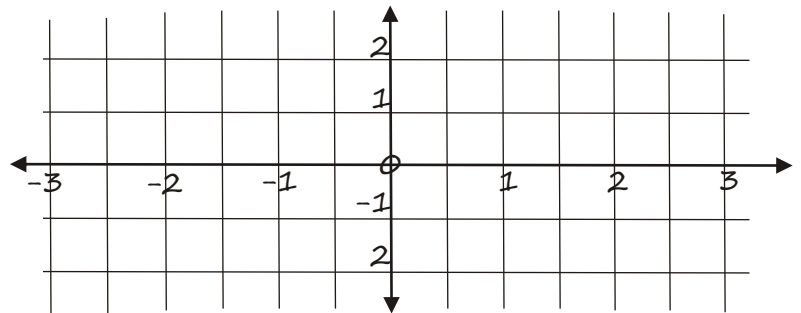

5. Draw graphs of the following equations:

a. $x + y = 3$

b. $2x + 5y = 20$

c. $y - 2x = 2$

d. $y = 3x - 2$

e. $y = -2x + 4$

f. $y = -4x + 1$

g. $y = \frac{3}{4}x - 5$

h. $y = -\frac{1}{4}x + 1$

i. $x = 6$

j. $y = 3.5$

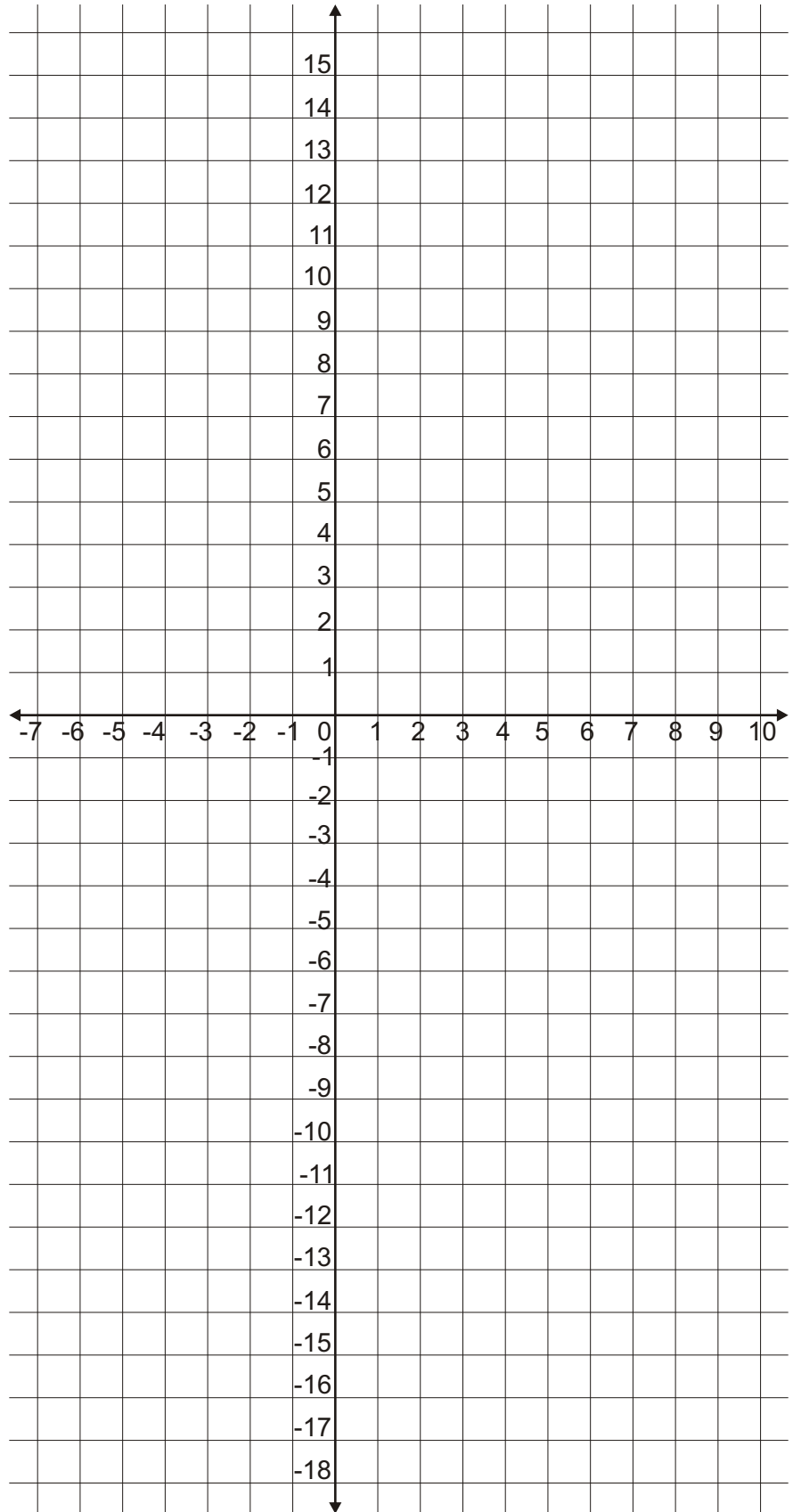

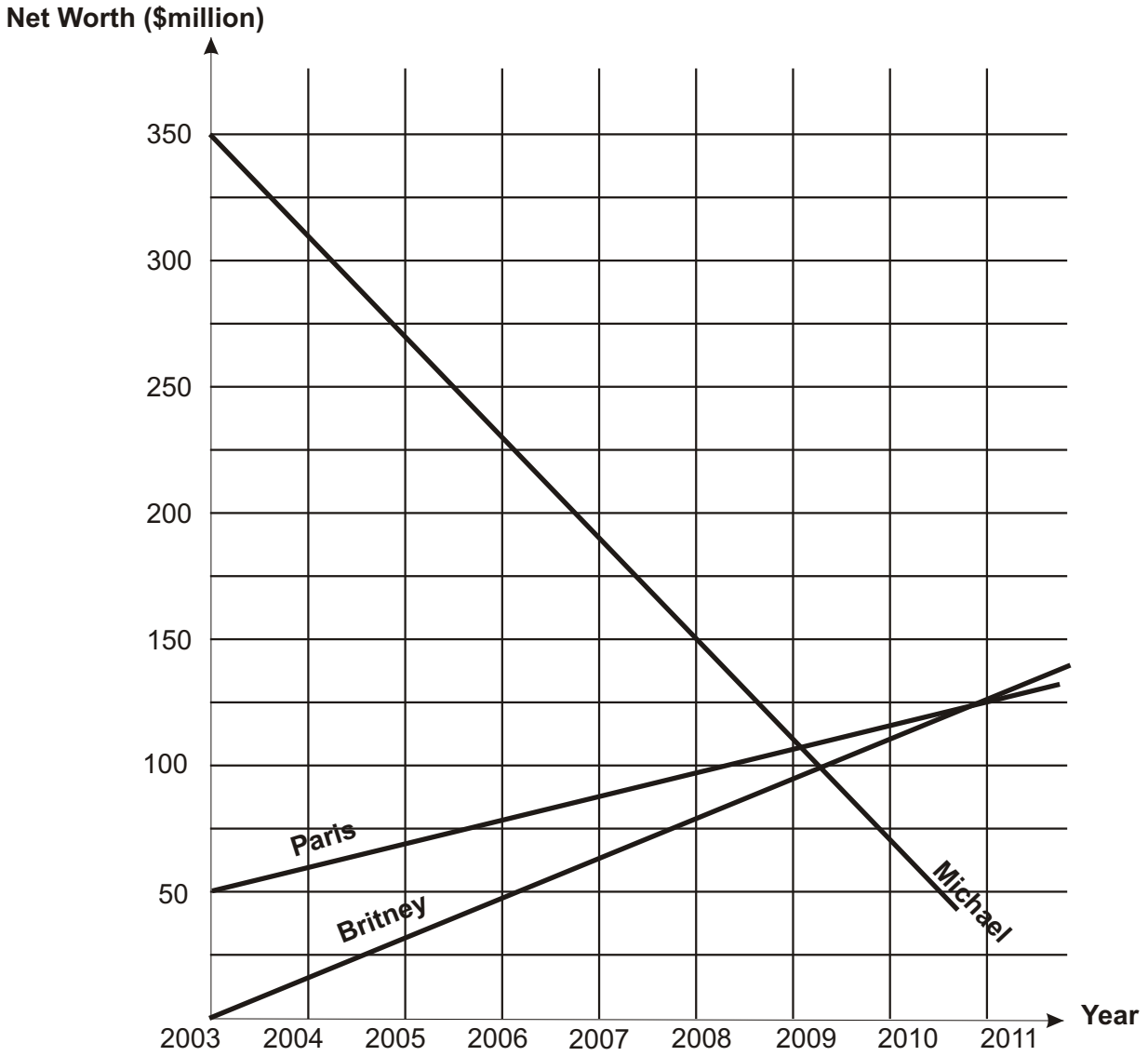

6. The graph shows the net worth of 3 famous siblings (Michael, Paris and Britney) who are all famous singers.

a. Who initially had the most successful career?

.....

b. At what annual rate is Britney’s and Paris’s net worth changing?

.....

c. Michael seems to be losing his net worth.
When do you estimate that he will be worth less than \$1 million?

.....



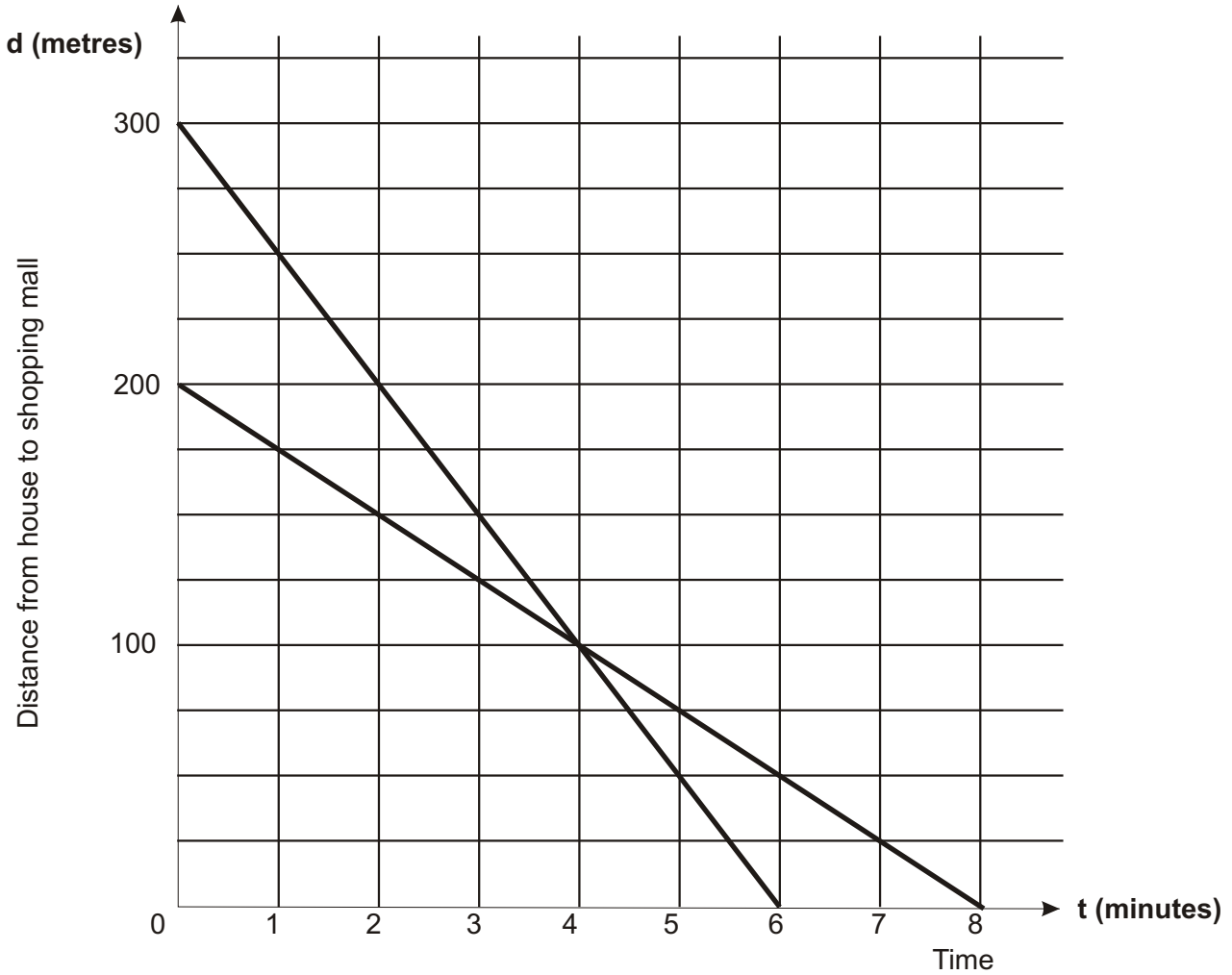

7. Britney runs from her house to the shopping mall.
 Paris walks from her home to the shopping mall.
 The distances and times taken are shown on the graph above.
- a. Which line represents Britney and which line represents Paris?
 Explain what each line tells us.
-
-
-
- b. Both Britney and Paris left their homes at 1.30pm to go to the mall.
 When would they be the same distance from the shopping mall?
-
-

8. Ramsey buys a 2.25 kg leg of pork for Sunday's roast dinner. Recipe books suggest that a pork roast be cooked at 120° C for 30 minutes plus 50 times the mass in kg (minutes). Complete the table and then draw a graph on the grid below that shows the cooking time for a roast.

x (kilograms)	0.5	1	2	3	4	5	
y (cooking time)	55						

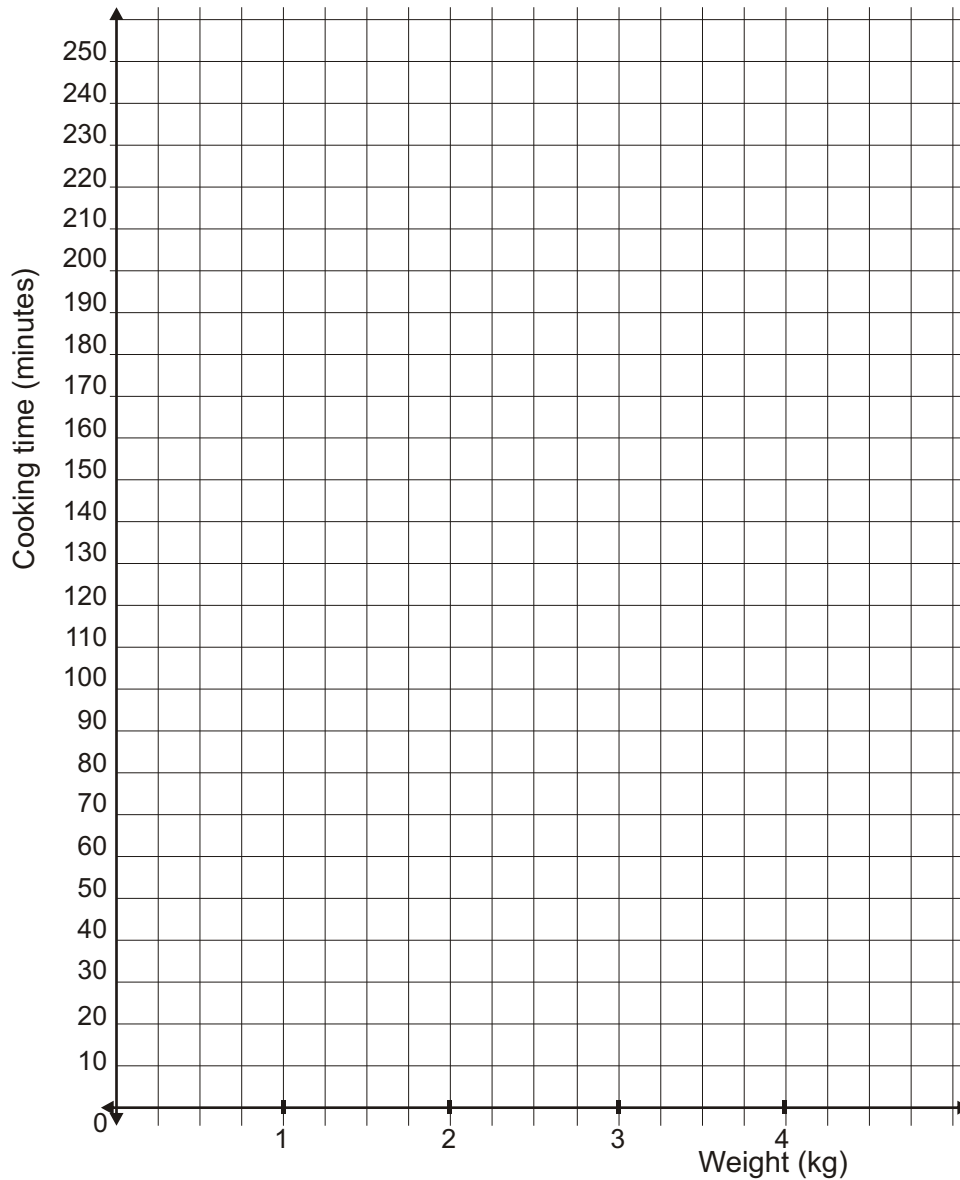

Give the equation of the line that you drew: *Equation*

Ramsey's mum has another method of calculating cooking time. She tells Ramsey to cook the roast for $2\frac{1}{4}$ hours - that's an hour for every kilogram. On your graph, draw another line that shows this new formula.

Compare the two lines and comment:

.....



9. Brad and Angie are travelling overseas. There are three international phone cards that they can buy:
1. More Talk
 2. Talk On
 3. Stay In Touch

The graph below shows the call costs for the More Talk and Talk On cards.

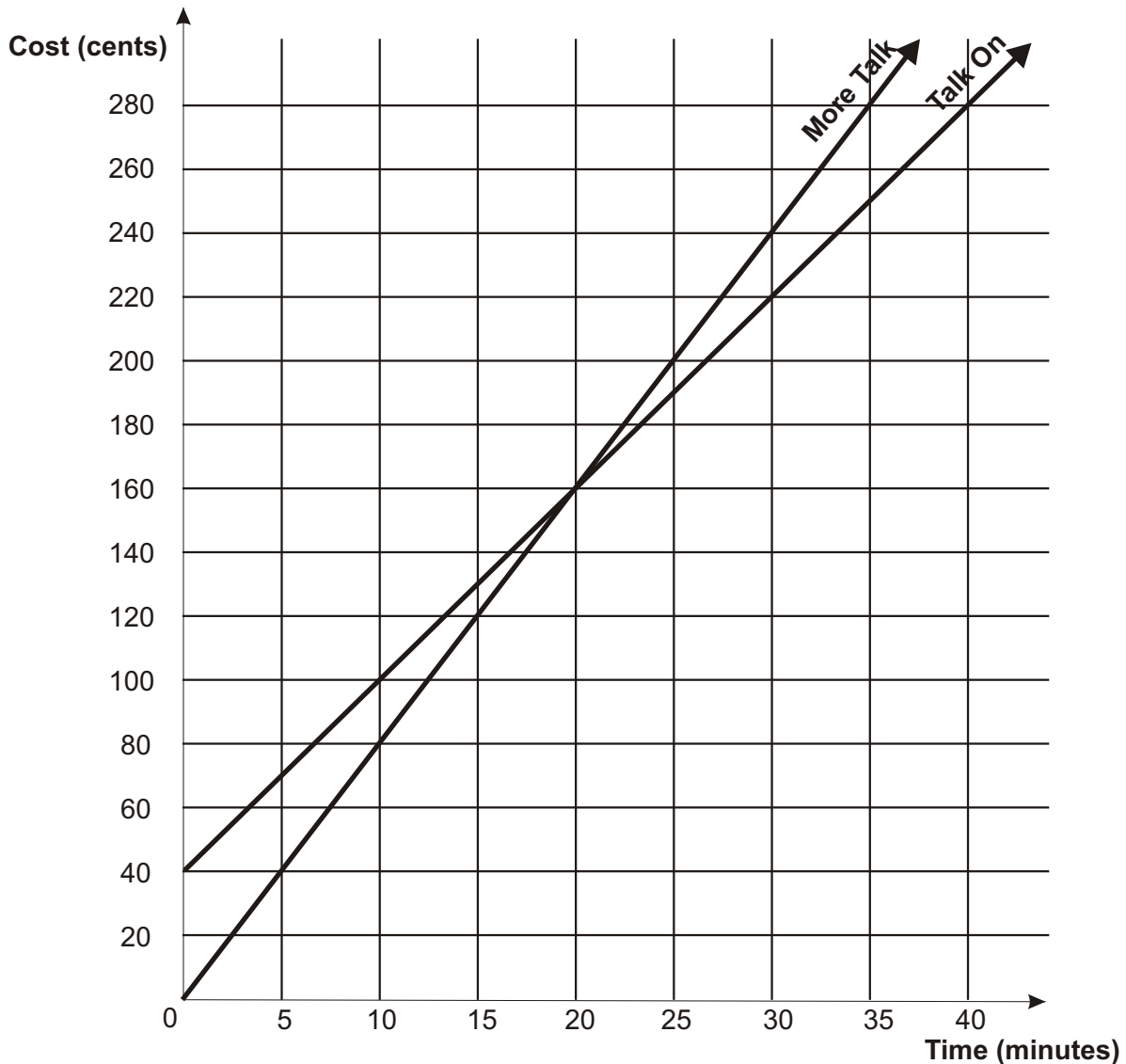

The Stay In Touch card costs 4 cents per minute plus a \$1 call connection fee. The cost per call using the Stay In Touch card can be described by the equation: $C = 4t + 100$ where

t = time (in minutes) for one call
 C = cost (in cents) per call

- a. On the axes, draw the graph for the Stay in Touch card from $t = 0$ minutes to $t = 30$ minutes.

b. i. Which ONE of the three phone cards has the highest connection fee per call?

.....

ii. How is this shown by the graphs?

.....

.....

c. i. How long is a call that costs the same using the More Talk card and the Talk On card?

.....

.....

ii. How is this shown by the graphs?

.....

.....

d. i. Use the graph to write the equation for the More Talk card.

.....

.....

C =

ii. Use the graph to write the equation for the Talk On card.

C =



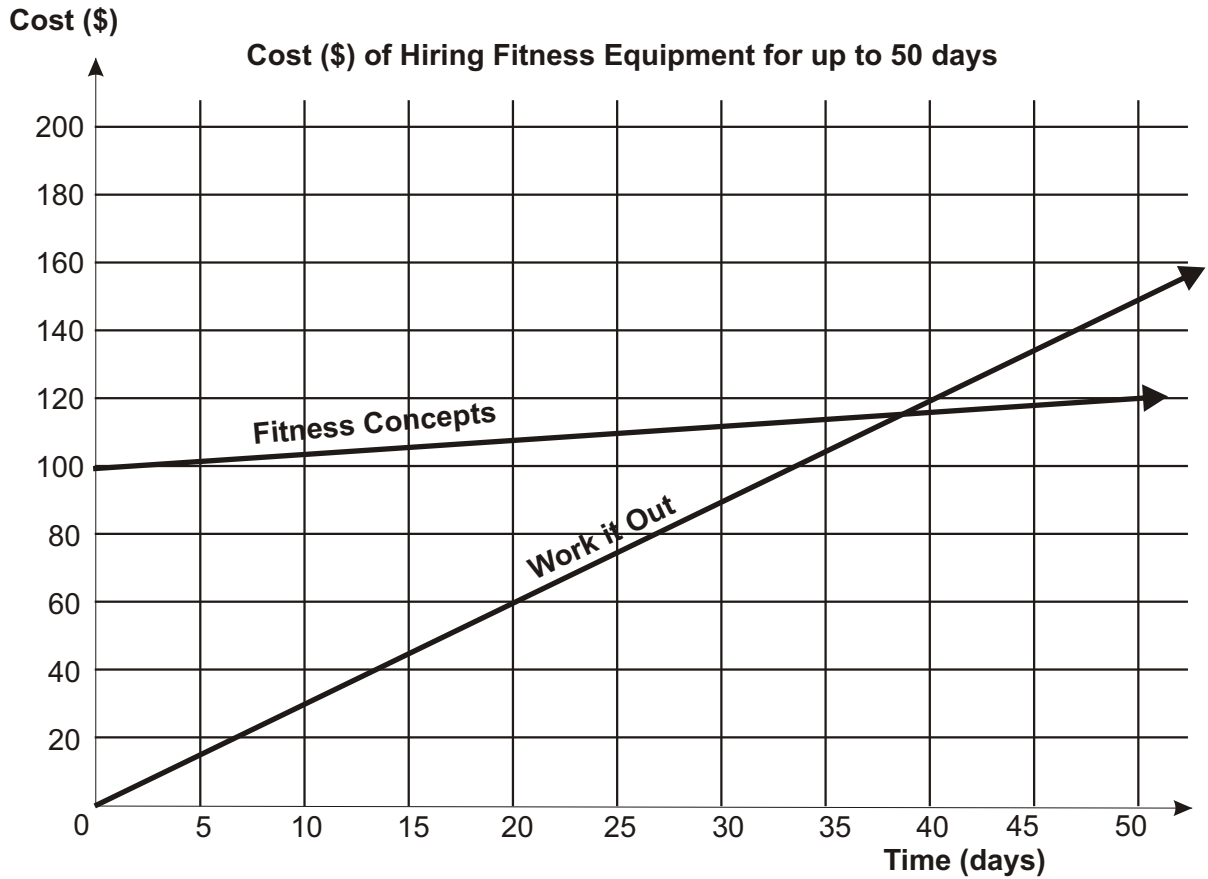

10. Terrence investigates the cost of hiring exercise equipment for his home. He phones 2 companies - 'Work it Out' and 'Fitness Concepts'. The graph above shows the cost of hiring the same equipment for up to 50 days.

a. What are the main features of each company's charges?

.....

.....

b. How much does Work it Out charge per day?

c. At Fitness Concepts there is a fixed fee plus a daily rate for each hire. How much is the fixed fee?

.....

d. Terrence decides to hire fitness equipment for 45 days. Which company should he use and why?

.....

.....

Merit Example - Straight Line Graphs

A new experimental diet for hens determines that the average weight (grams) of a hen can increase in a linear (straight line) fashion over a period of 50 days.

The average mass of a hen starting the diet is 150 grams.

After 30 days the average mass is 690 grams.

- a. Draw a graph of this situation and give the equation of the line formed.

At Day 0 the hens mass is 150 grams i.e. (0, 150)

At Day 30 the hen's weight is 690 grams, i.e. (30, 690)

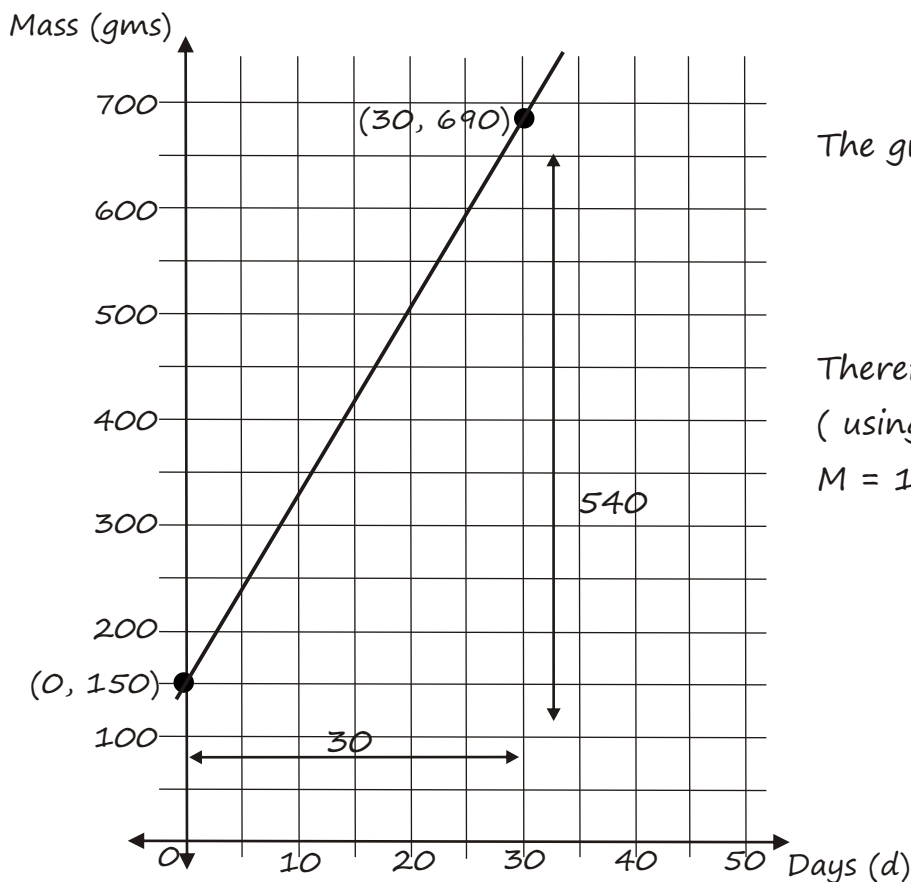

The gradient of the line

$$= \frac{540}{30}$$

$$= 18$$

Therefore equation of the line:

(using $y = mx + c$)

$$M = 18d + 150$$

- b. Use your equation to find the average weight of a hen after 10 days.

$$\text{Using } M = 18d + 150 \quad \gg \quad M = 18(10) + 150$$

$$M = 330 \text{ grams}$$

- c. A supermarket wants a shipment of chickens that have a mass of 1kg. When will the hens reach an average weight of 1 kg?

$$\text{Using } 1000 = 18d + 150 \quad \gg \quad 850 = 18d$$

$$d = 47.2 \text{ days.}$$

Within 48 days of starting the diet, the hens will be 1 kg.



Quadratic Graphs

The graph of a quadratic equation forms a curve called a parabola. The quadratic equation can have the form $y = ax^2 + bx + c$ or be in factored form $y = (x + m)(x + n)$.

Some examples of quadratic functions that form parabola are: $y = 5(x - 2)^2 + 3$

$$y = x^2 + 4$$

$$y = 2x^2 - 3x - 6$$

Drawing a Parabola

If you are unsure then the best method of graphing any sort of function is to draw up a table and plot the points. e.g. Draw a graph of the function $y = 2x^2 - 8$

x	-3	-2	-1	0	1	2	3
$2x^2$	18	8	2	0	2	8	18
-8	-8	-8	-8	-8	-8	-8	-8
$y = 2x^2 - 8$	10	0	-6	-8	-6	0	10

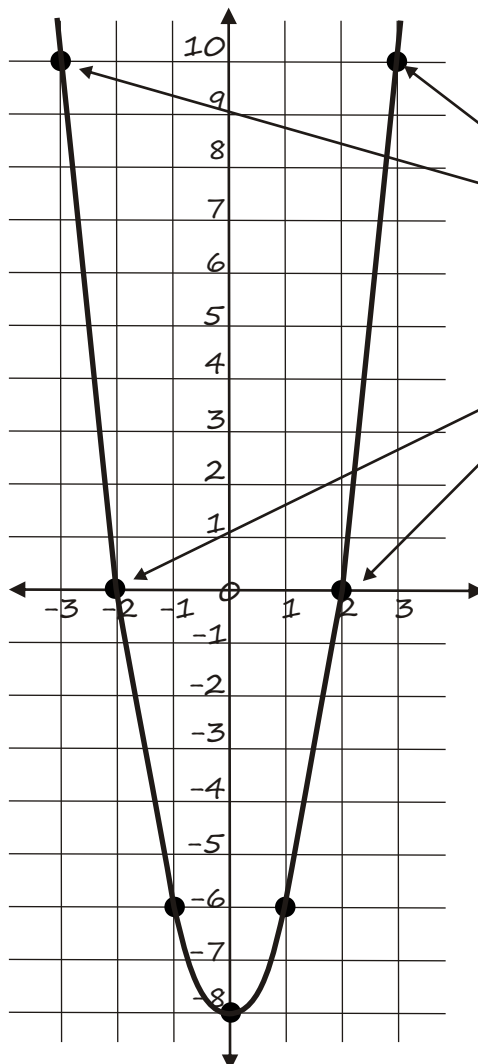

Notice how the points mirror each other. If they don't then something is wrong with your graph.

A sketched parabola should be a smooth, symmetric curve with intercepts, vertex and other points clearly labeled.

Drawing a Parabola from Factorised Quadratics

e.g. Draw the graph of the equation $y = (x - 5)(x + 3)$

1. Work out the x intercepts (when $y = 0$) i.e. $(5, 0)(-3, 0)$

2. Work out the turning point i.e. The midpoint between the intercepts $(5 + -3) \div 2 = 1$. Then work out the y value of the turning point i.e. $y = (1 - 5)(1 + 4)$,

$$y = -16 \text{ i.e. Turning point is } (1, -16)$$

3. Work out the y intercept ($x = 0$)

$$y = (0 - 5)(0 + 3)$$

$$y = -15 \text{ i.e. } y \text{ intercept is } (0, -15)$$

The parabola is drawn below. For more values you could extend the x axes and work out the values of y for $x = \{-4, -5, \dots\}$ or $x = \{6, 7, \dots\}$

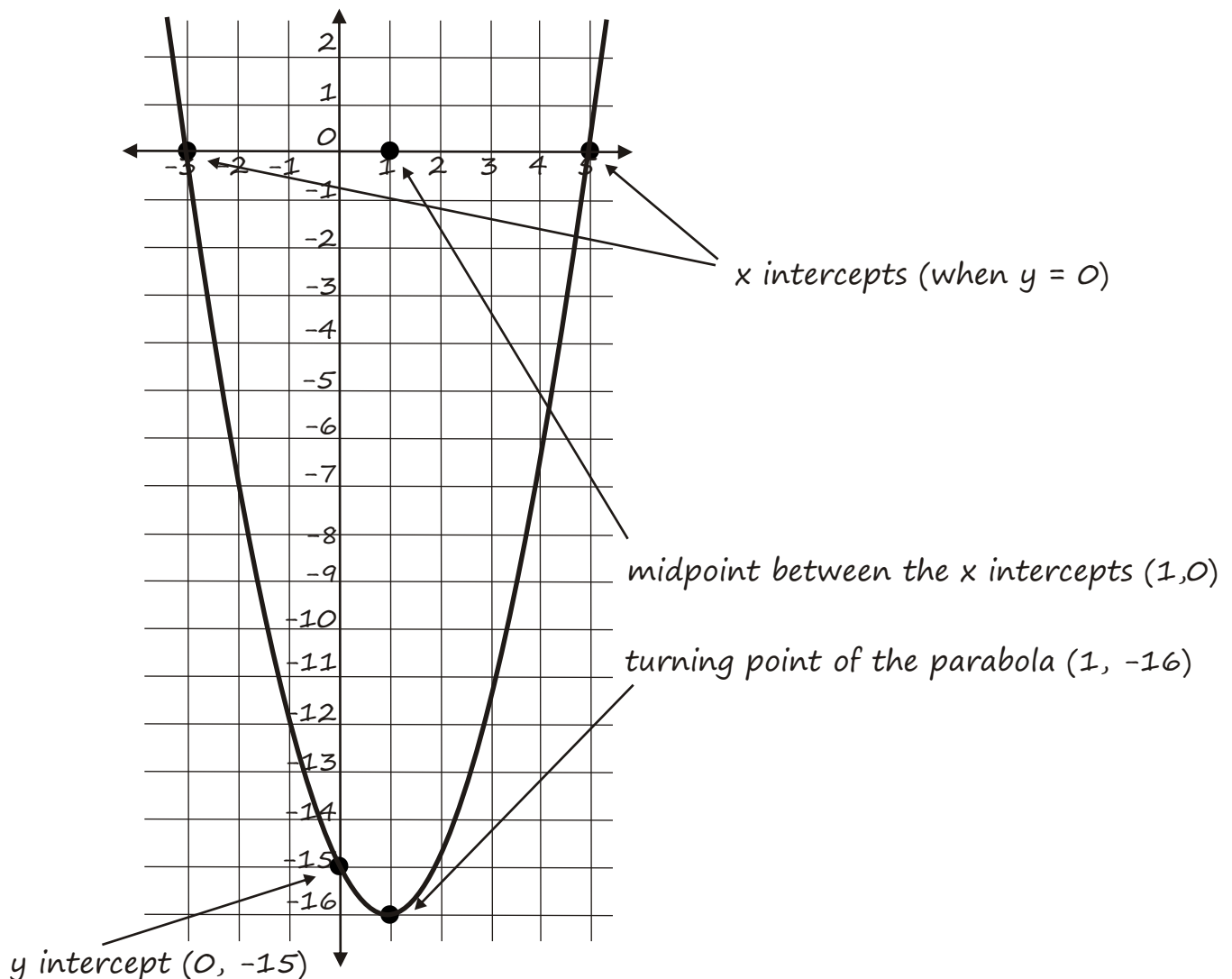

Transforming Quadratic Graphs

Quadratics and parabolas come in many forms. Below are some common quadratic equation forms. Compare the first graph of the equation $y = x^2$ to all the others.

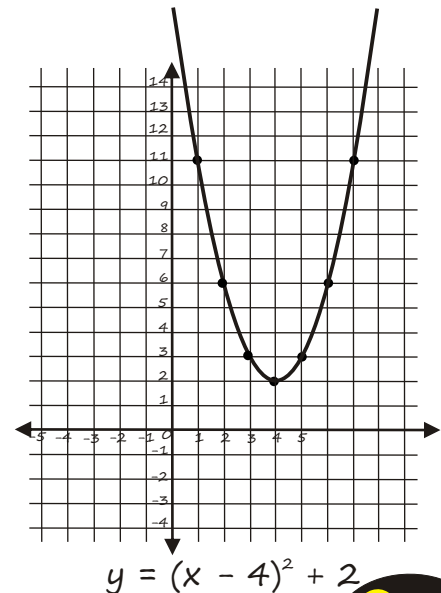
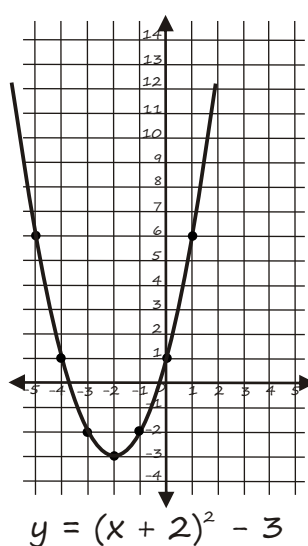
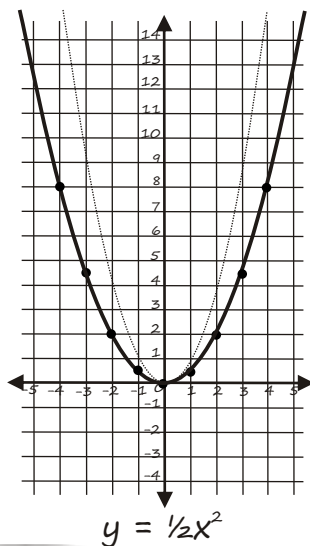
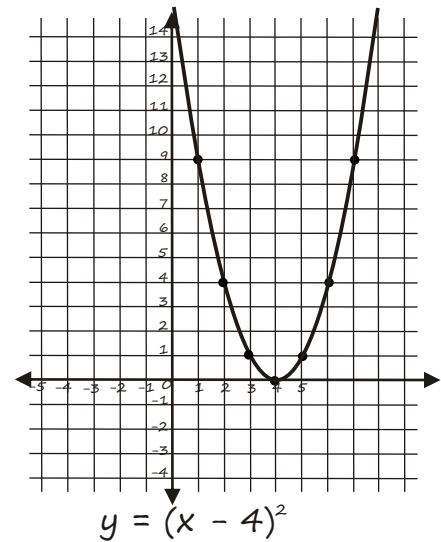
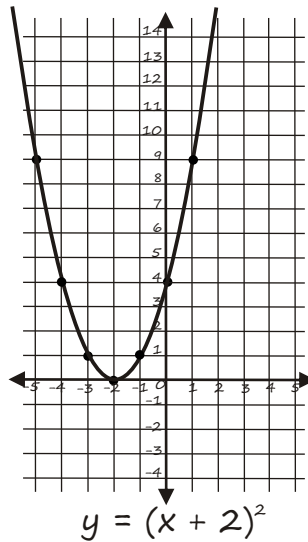
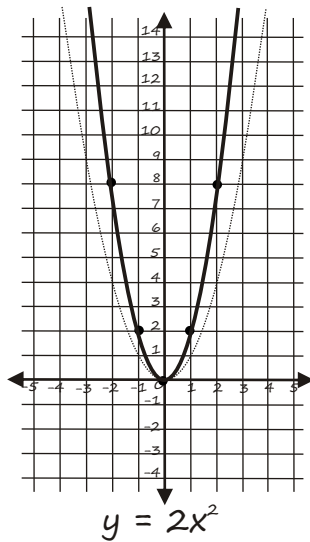
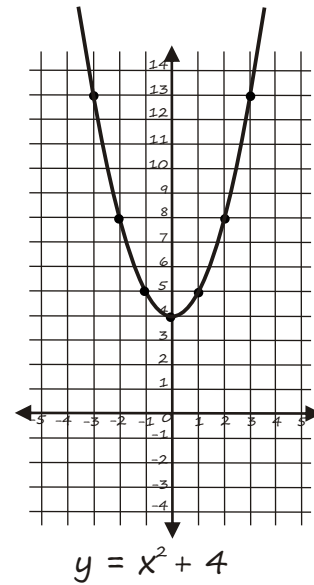
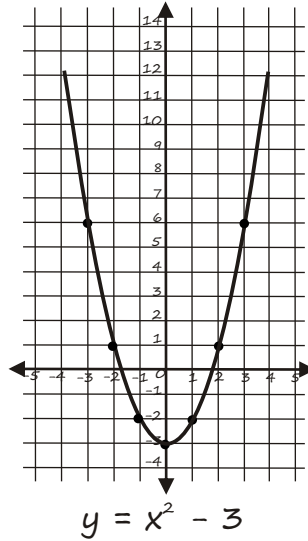
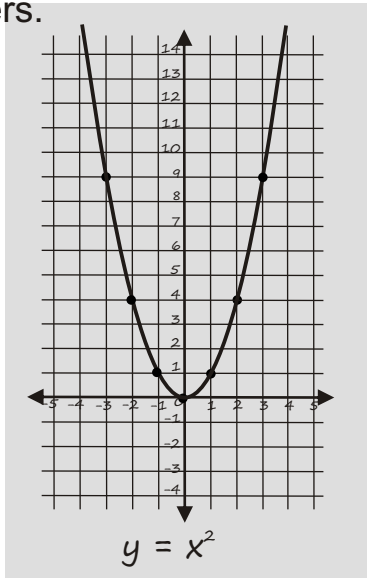

Exercises

1. Draw these graphs.

a. $y = x(x - 2)$

b. $y = 2x^2 - 8$

c. $y = -x(x - 1) - 3$

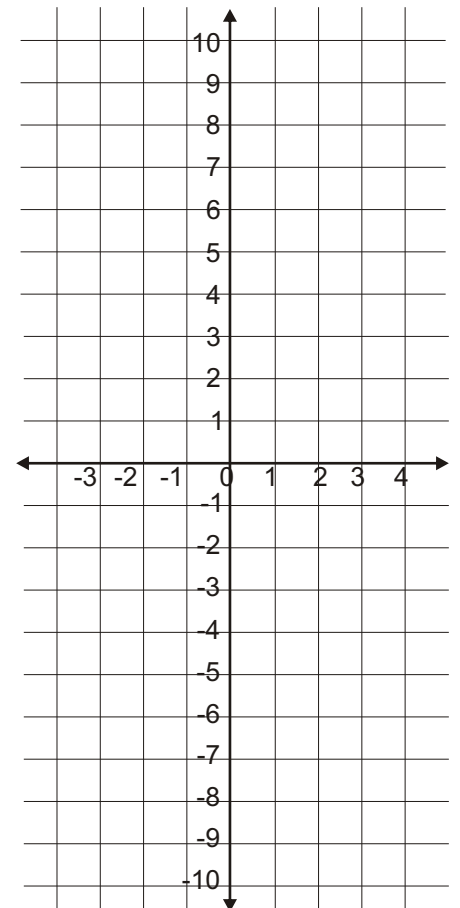
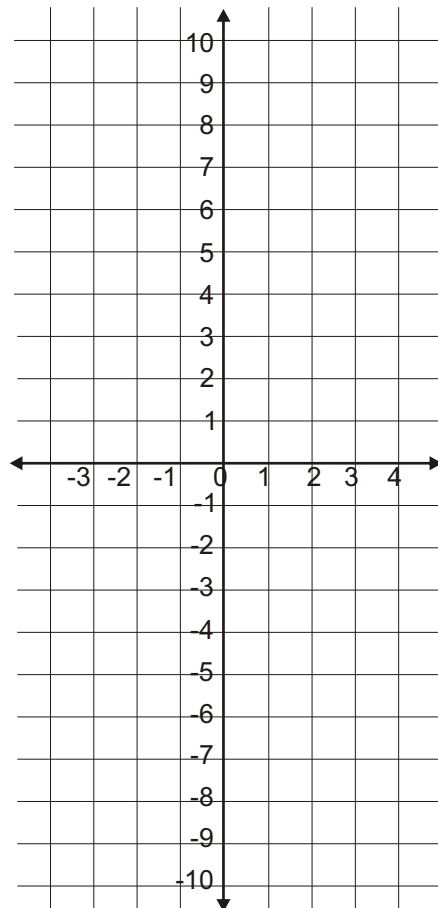
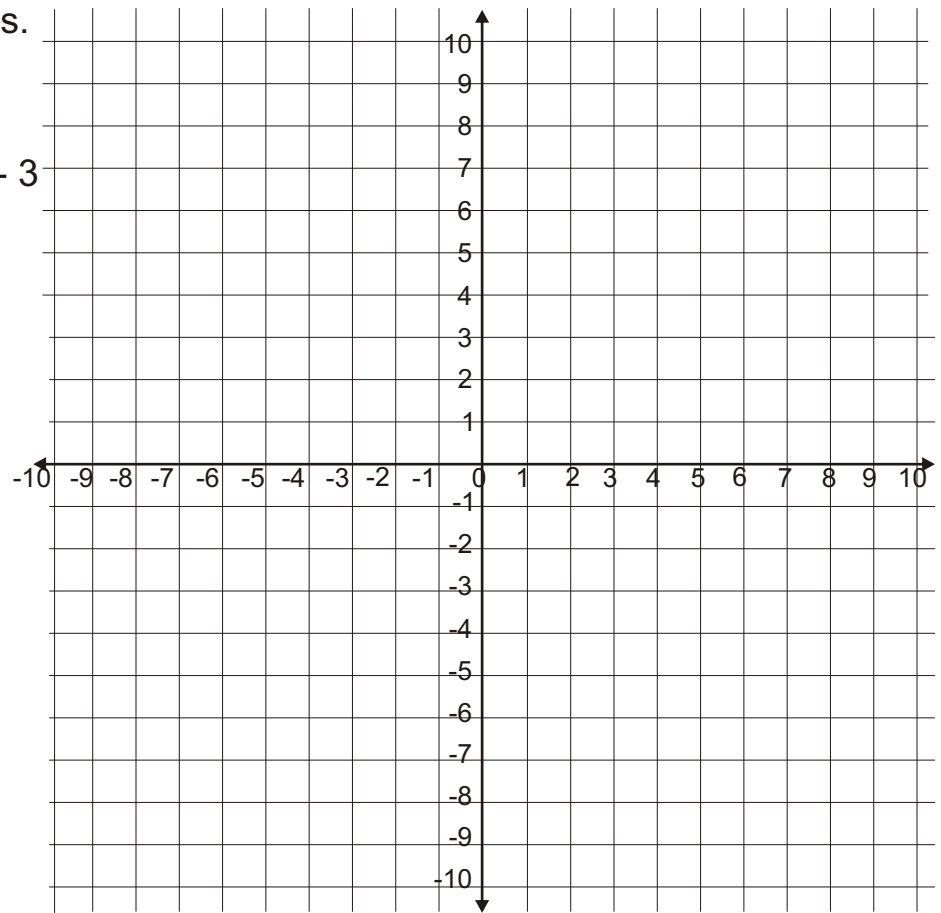

d. $y = (x - 2)(x + 4)$

e. $y = 2 + x - x^2$

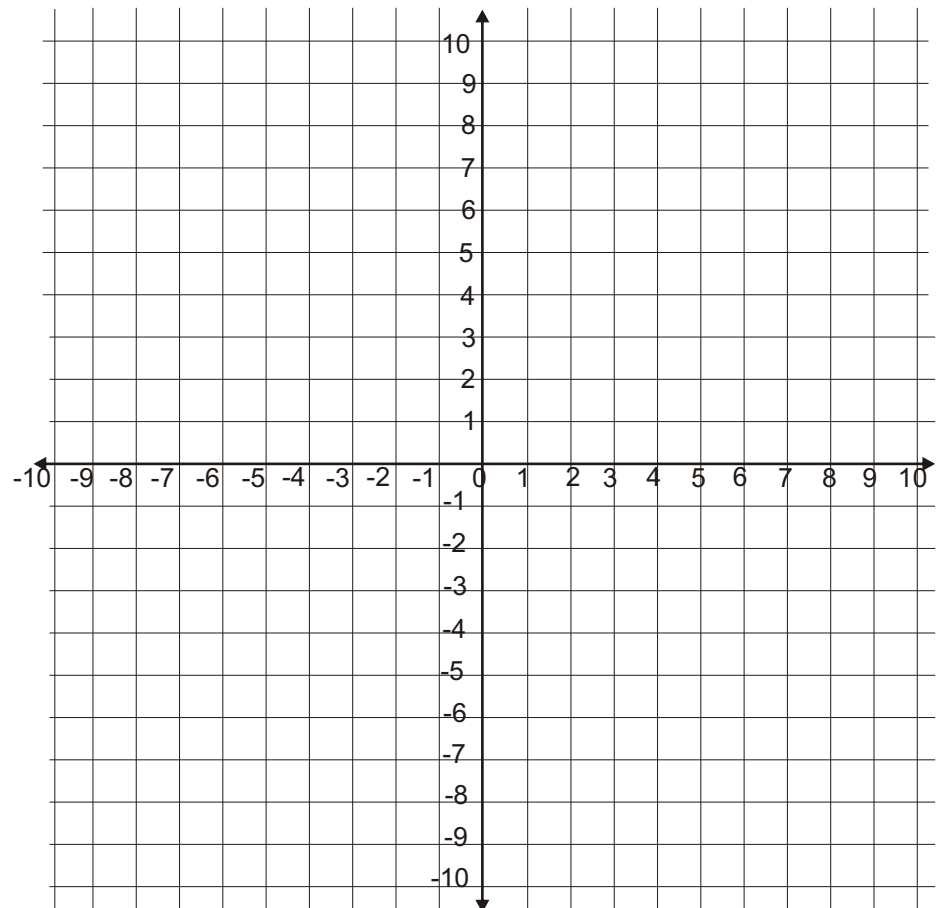
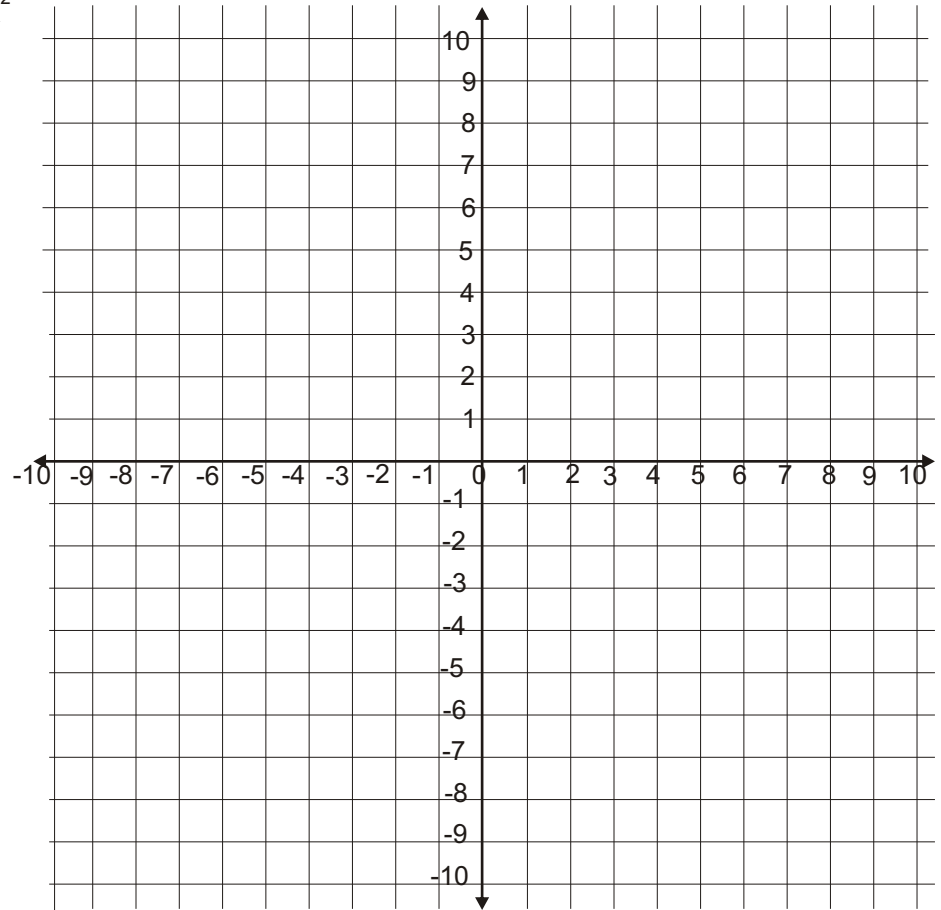

2. Sketch the graphs of the following functions, clearly marking all intercepts, the axis of symmetry and the vertex of the curve:

a. $y = x^2 - 7x + 6$

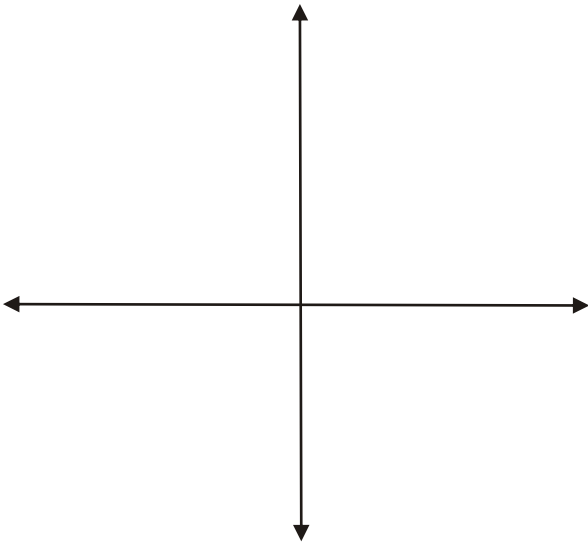

b. $y = x^2 + 8x - 20$

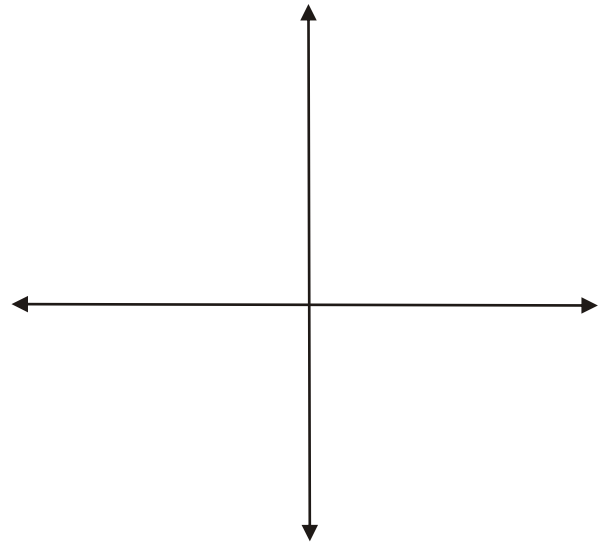

c. $y = x^2 - 2x - 35$

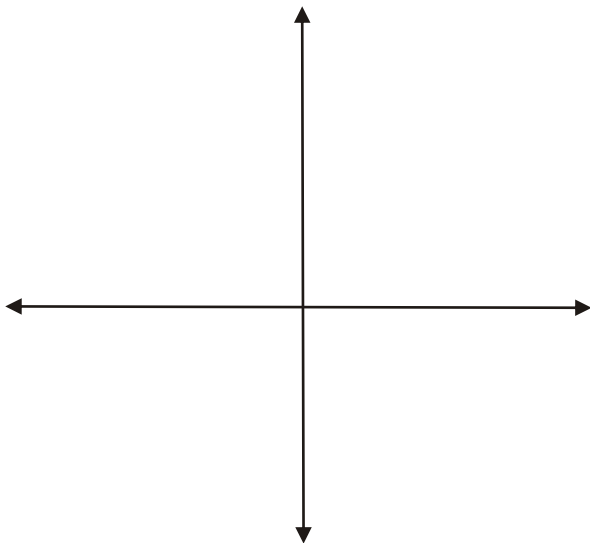

d. $y = x^2 - 3x$

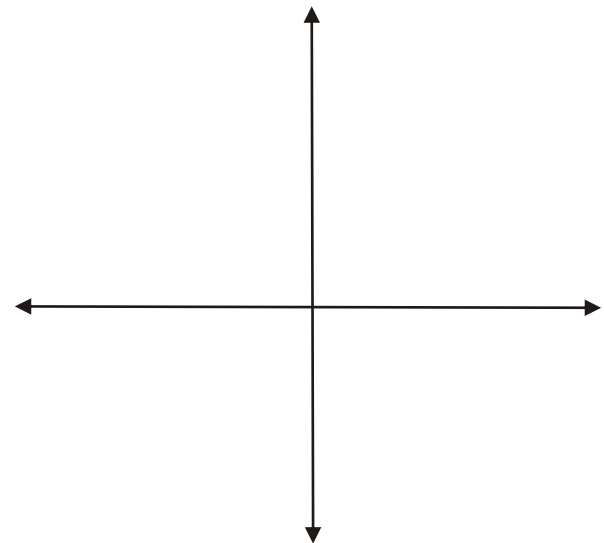

3. The sketch is of the function: $y = (x - 2)(x + 3)$.
Write the co-ordinates of the points A, B, C, D and E.

A = (..... ,)

B = (..... ,)

C = (..... ,)

D = (..... ,)

E = (..... ,)

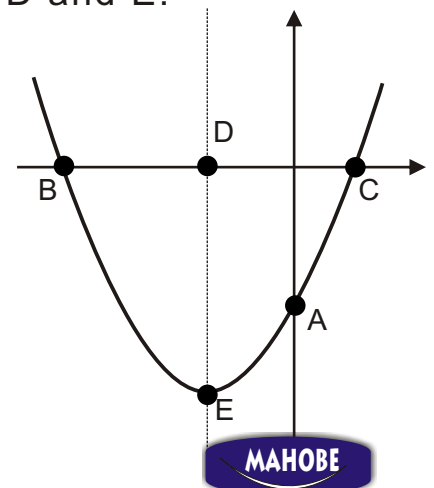

4. The graph below shows part of a race track. The unmarked section between points A and B is being redesigned into the shape of a parabola. This section can be drawn by the equation: $y = (x + 3)(x - 2)$

Complete the table then joint the points between A and B to show the completed track.

x	-2	-1	0	1	2	3
(x + 3)						
(x - 2)						
(x + 3)(x - 2)						

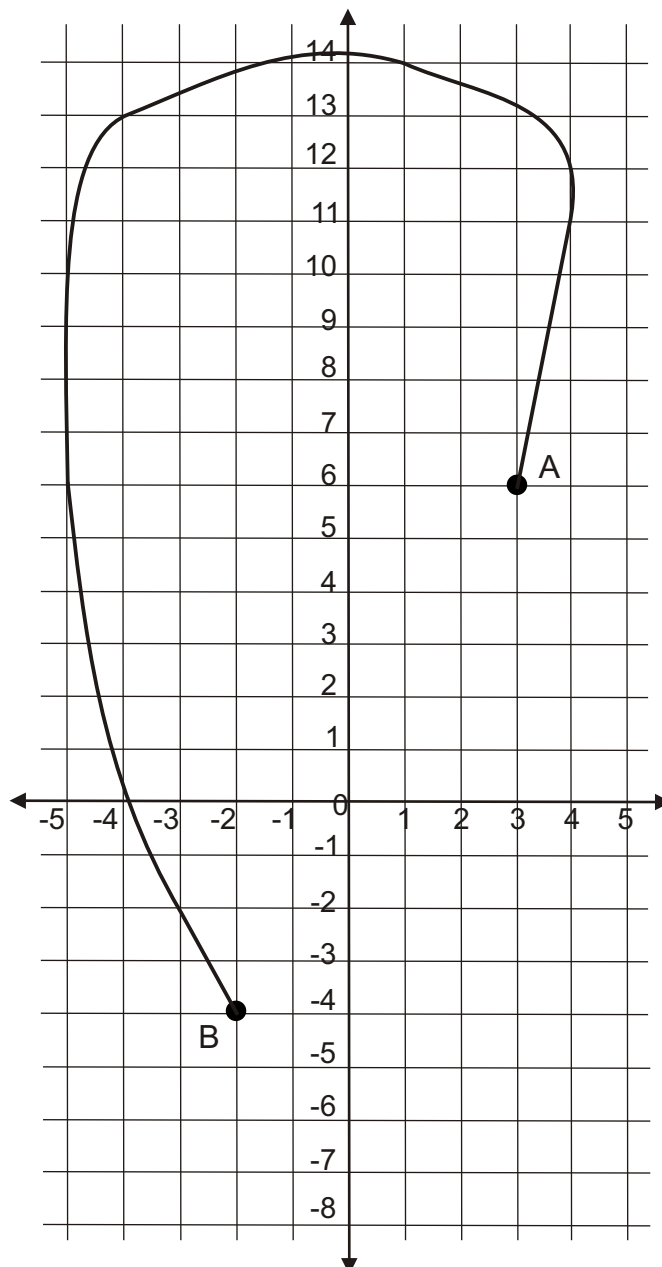

Quadratic Graphs - Merit Example

A stone is fired from a catapult. The height gained by the stone is given by the equation $h = 25t - 5t^2$. (h = height of the stone, t = time in seconds.)

- At what times is the stone at a height of 25 metres?
- What is the stone's height after 2.5 seconds.

Draw up a table then plot the points on a graph.

t	<u>0</u>	<u>1</u>	<u>2</u>	<u>3</u>	<u>4</u>	<u>5</u>
$25t$	0	25	50	75	100	125
$-5t^2$	<u>0</u>	<u>-5</u>	<u>-20</u>	<u>-45</u>	<u>-80</u>	<u>-125</u>
$H = 25t - 5t^2$	0	20	30	30	20	0

Height (metres)

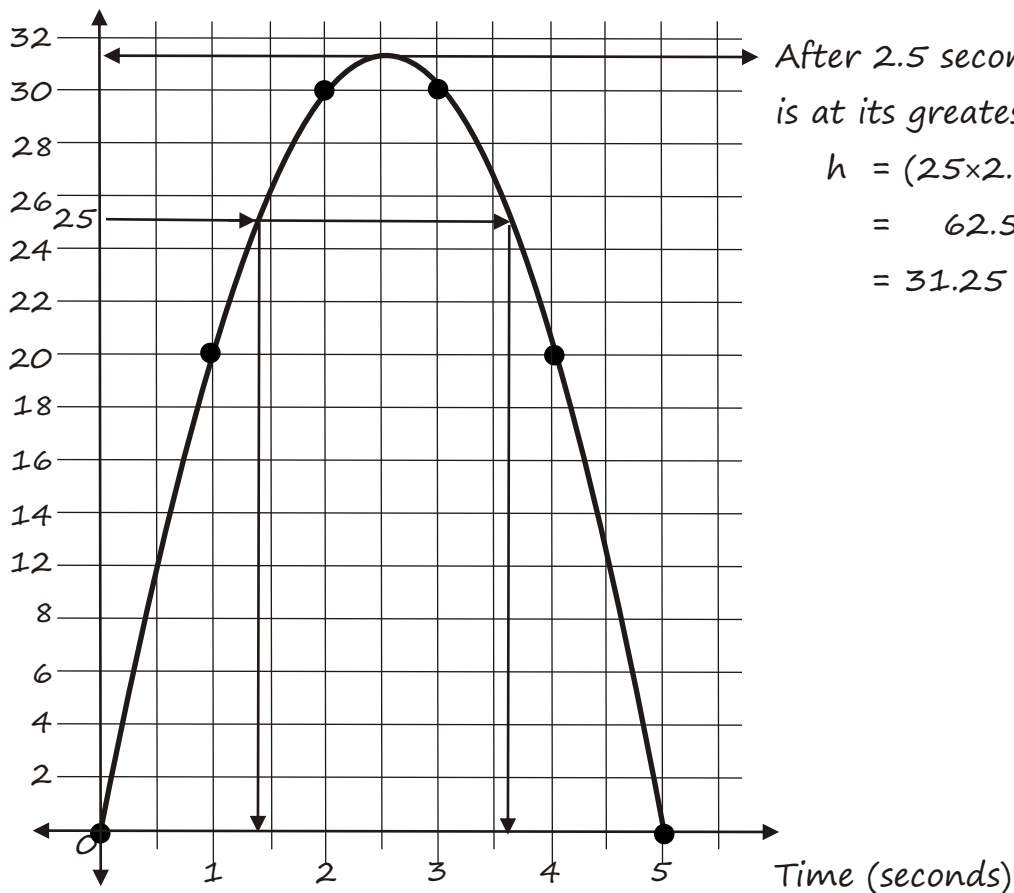

After 2.5 seconds the stone is at its greatest height:

$$\begin{aligned} h &= (25 \times 2.5) - (5 \times 2.5^2) \\ &= 62.5 - 31.25 \\ &= 31.25 \text{ m} \end{aligned}$$

The stone is at a height of 25 metres after 1.4s and 3.6s

Check with the original equation: $h = 25t - 5t^2$

$$25 = 25 \times 1.4 - 5 \times 1.4^2$$

$$25 = 25 \times 3.6 - 5 \times 3.6^2$$



Quadratic Graphs - Merit Example

Owen and Becks are playing football. Owen receives a pass and quickly kicks the ball towards Becks. The graph below shows the path of the ball as it travels from Owen to Becks. The graph has the equation $y = 0.1(5-x)(x + 1)$.

The graph is not drawn to scale.

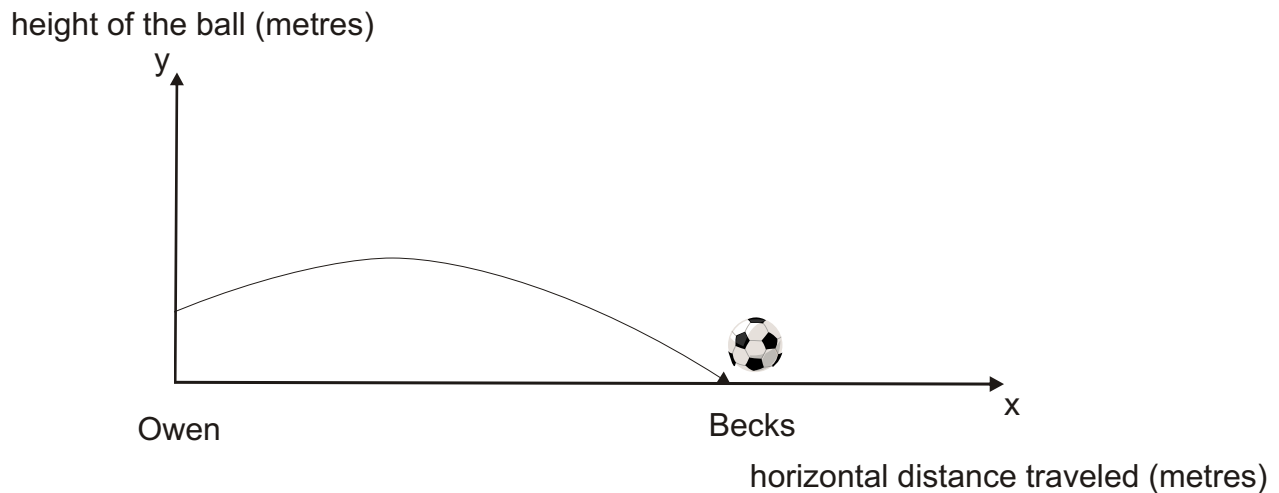

- a. Write down the value of the y-intercept and explain what the value represents.

The y intercept is when $x = 0$. It represents the initial height that the ball was when Owen kicked it. Therefore put $x = 0$ into the equation.

$$y = 0.1(5-x)(x + 1)$$

$$y = 0.1(5) \times (1)$$

$$y = 0.5$$

Owen kicked the ball to Becks when it was at a height of 0.5m

- b. What height does the ball reach above the ground?

The midpoint of the parabola graph is midway between 5 and -1. These are the x intercepts (when $y = 0$).

This means that the maximum height (midpoint) is at:

$(5 + -1) \div 2 = 2$, put this value into the equation:

$$y = 0.1(5 - 2)(2 + 1)$$

$$y = 0.1 \times 3 \times 3$$

$$y = 0.9 \text{ metres above the ground}$$



5. Mary-Kate is trying to solve the equation $x^2 - 3x = 1$. She tries different values at random such as $x = 3$ but cannot find a solution.

a. Draw the graph of $y = x^2 - 3x$ using the x values from -1 to 4.

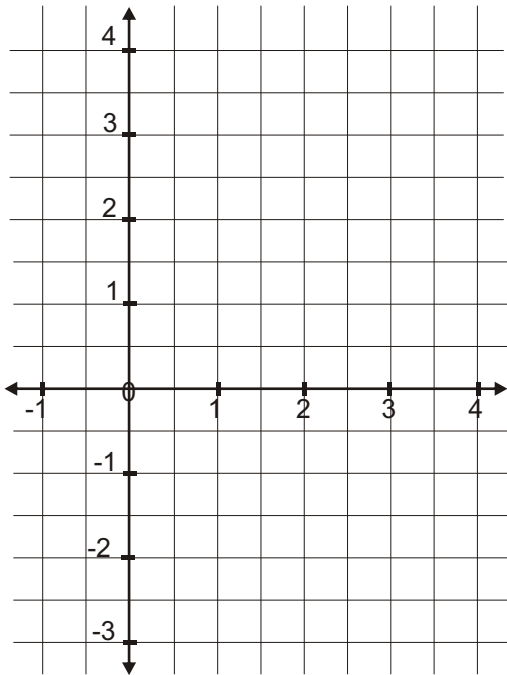

b. By drawing a suitable line on the graph above show the solution to the equation $x^2 - 3x = 1$.
How many solutions are there?

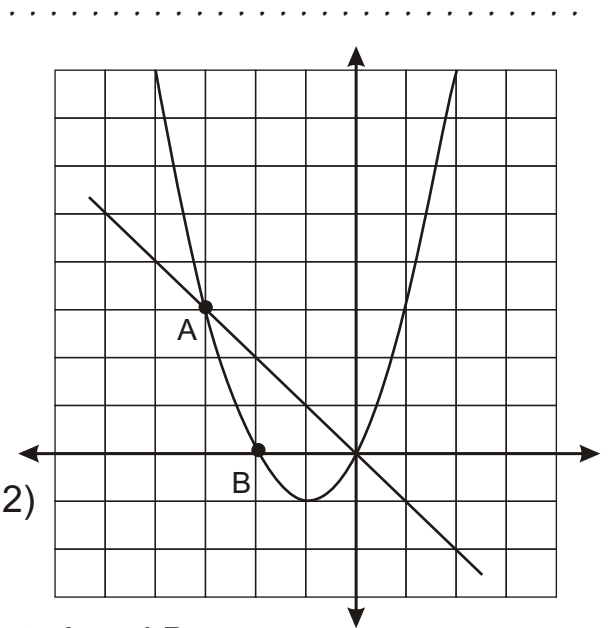

c. The graphs of $y = -x$ and $y = x(x + 2)$ are shown on the right.

Write down the co-ordinates of points A and B.

A = (..... ,) B = (..... ,)

d. Write down any other co-ordinate on the curve $y = x(x + 2)$.

Co-ordinate = (..... ,)

e. The line $y = 2x + 4$ passes through point B.
What is the gradient of the line $y = 2x + 4$?

Gradient =

f. On the diagram, draw in the line $y = 2x + 4$.
Find other intersection points of the parabola and the line $y = 2x + 4$.

.....

6. Michael throws a cricket ball. The height of the ball follows the equation: $h = 20x - 4x^2$ where h = the height in metres that the ball reaches and x is the time in seconds that the ball is in the air.

a. Complete the shaded areas of the table below for the equation:
 $h = 20x - 4x^2$

x	0	1	2		3	4	5	6
20x	0	20						
- 4x ²	-0	-4						
20x - 4x ²	0	16						

b. Use the results of the table to draw a graph of $h = 20x - 4x^2$.

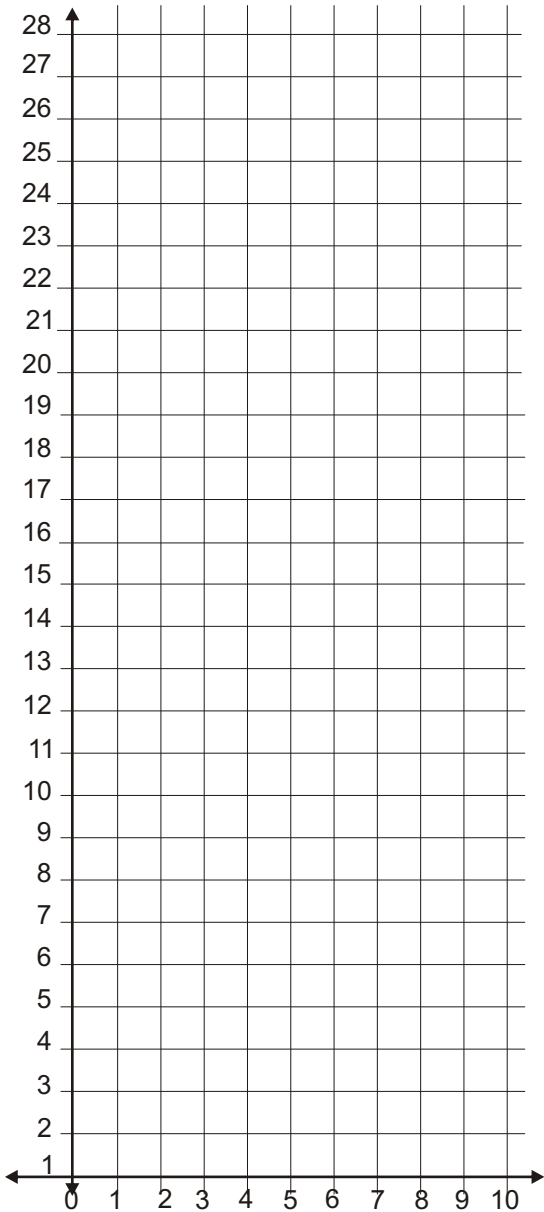

c. Describe what happens to the ball.
 e.g. What is the greatest height?
 How long is it in the air?

.....

.....

.....

.....

d. What happens to the ball after five seconds?

.....

.....

.....



7. An architect is designing a block of business units. The roof line is made from a series of parabolic shapes - 2 complete parabolas and two half parabolas.

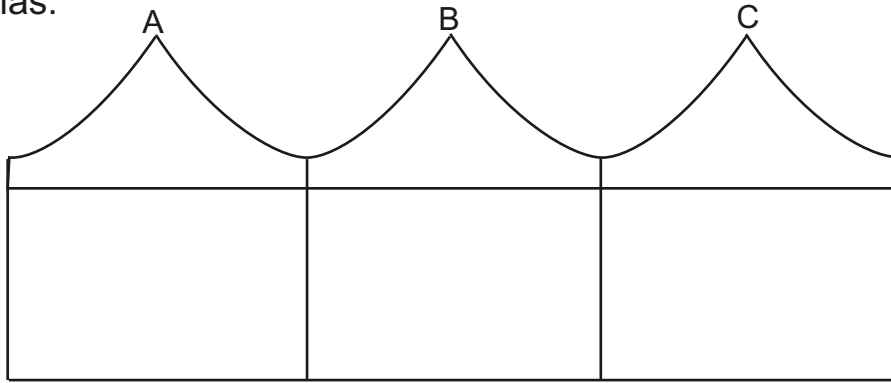

- a. The equation of the parabola between the points A and B is:

$$y = \frac{x^2}{2} - 5$$

Use this equation to complete the table of values.

x	-3	-2	-1	0	1	2	3
$\frac{x^2}{2}$	4.5	2					
-5	-5	-5	-5	-5	-5	-5	-5
y	-0.5	-3					

- b. A and B are two of the peaks of the roof. Plot all the points from your table of values above and draw the parabola.

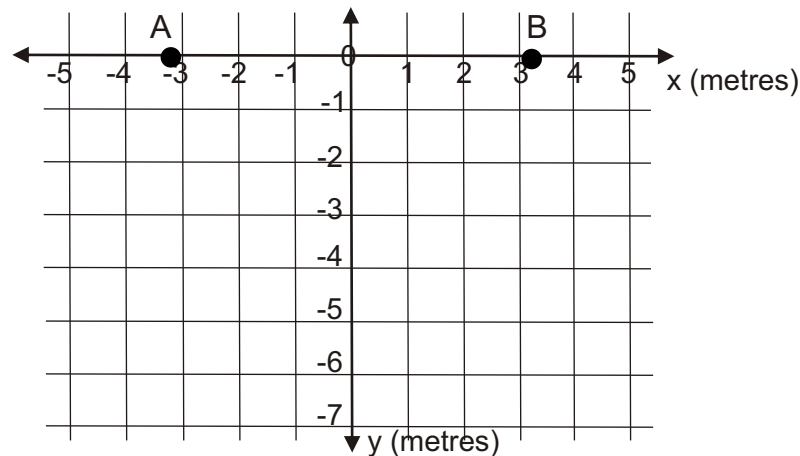

- c. Solve the equation $\frac{x^2}{2} - 5 = 0$, and use the solution to find the total width of the roof.
-

8. A road tunnel is shaped in the form of a parabolic arc. The tunnel can carry 2 lanes of traffic. It has a span of 12 metres and is 9 metres high at the vertex. The equation of the parabola is $x^2 = -4(y - 9)$.

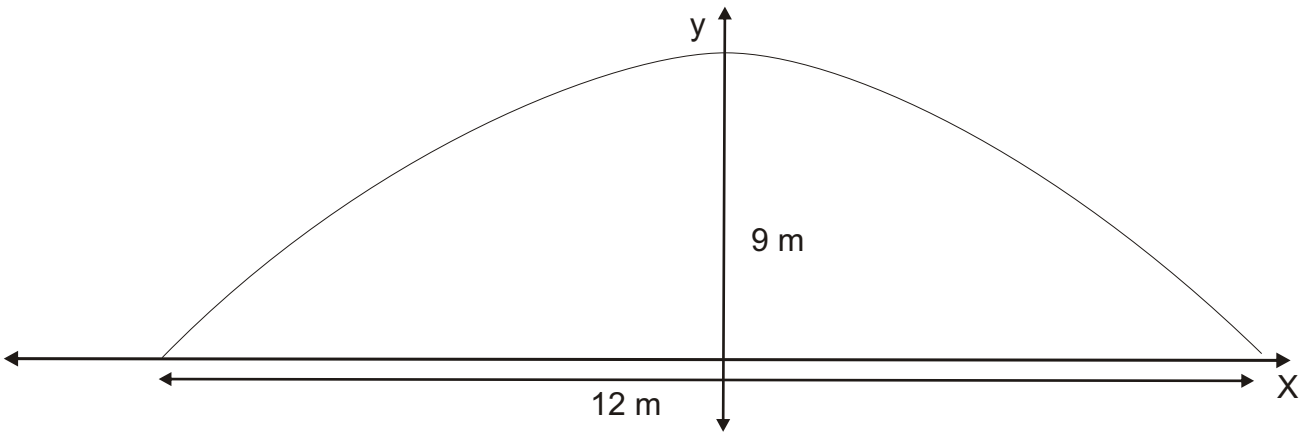

A container truck wishes to drive down one side of the tunnel. The truck is 7 metres high and 4 metres wide. Can it safely travel through the tunnel?

.....

.....

.....

.....

.....

.....

.....

.....

.....

.....

.....



9. A theme park roller-coaster ride includes a parabolic shaped drop into a tunnel from a height of 45m.

This drop can be modelled by $y = x^2 - 14x + 45$.

- a. On the grid below sketch the graph of: $y = x^2 - 14x + 45$.
Show all intercepts and the turning point (vertex) clearly.

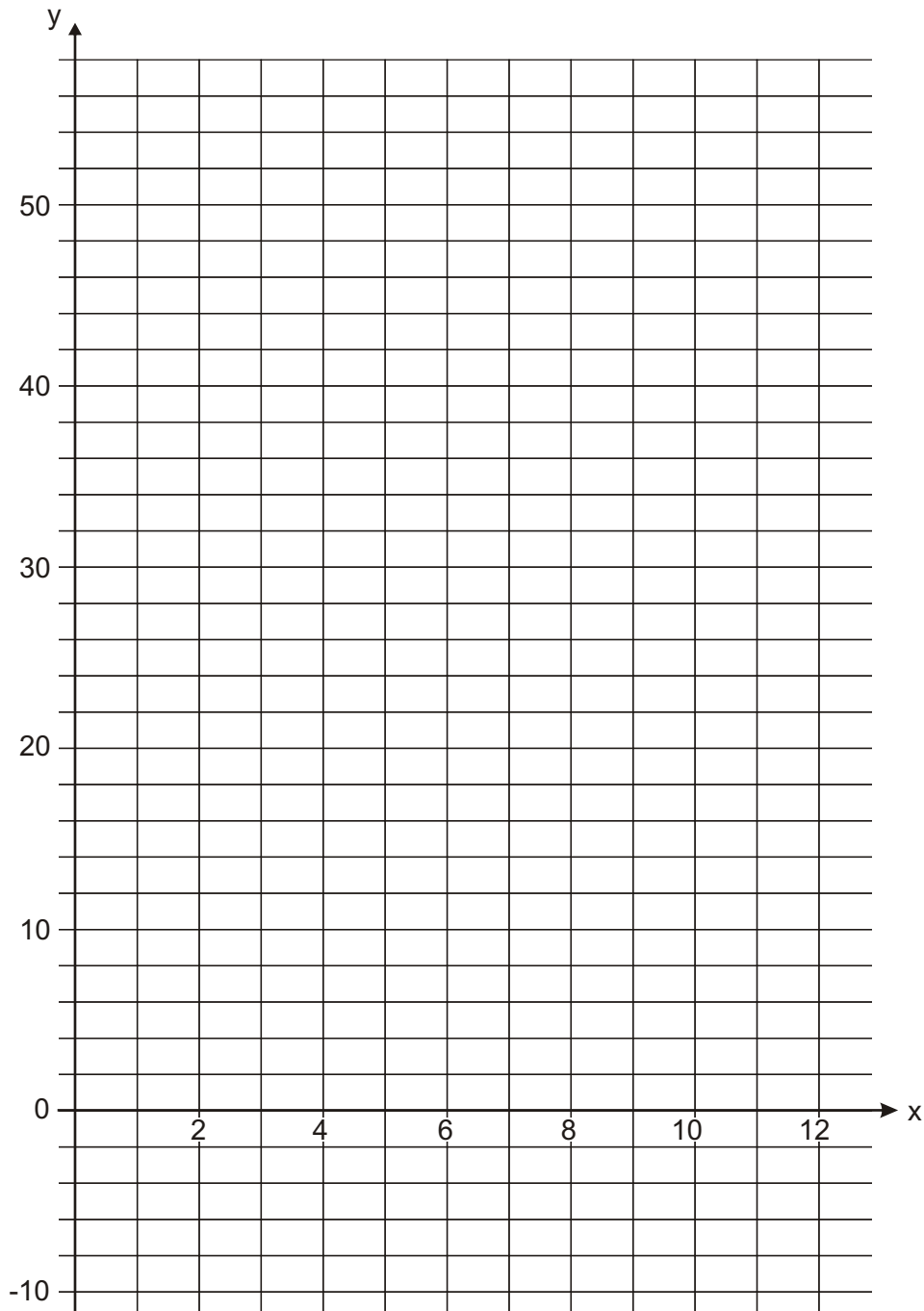

b. Where does the bottom of the drop occur?

.....

.....

c. How many metres does the roller coaster drop from top to bottom?

.....

.....

.....

.....

d. Use your graph to find the solutions to $x^2 - 14x + 45 = 0$.

.....

.....

.....

.....

e. Write $y = x^2 - 14x + 45$ in the form $y = (x + a)^2 + b$.

.....

.....

.....

.....



Finding the Equation of a Parabola

The standard form of a parabola is: $y = ax^2 + bx + c$.

If $a > 0$ (i.e. positive - then the parabola opens upwards \cup).

If $a < 0$ (i.e. negative - then the parabola opens downwards \cap).

If $|a| > 1$, the graph widens, if $|a| < 1$, the graph narrows.

The vertex form of a parabola is $y = a(x - h)^2 + k$, where (h, k) is the vertex.

e.g. a. The graph below shows a parabola $y = ax^2 + bx + c$, where $a = 1$.

Find the values of b and c by using $y = a(x - h)^2 + k$

The vertex $(h, k) = (3, 4)$, $a = 1$.

Therefore $y = (x - 3)^2 + 4$

$$y = x^2 - 6x + 9 + 4$$

$$y = x^2 - 6x + 13$$

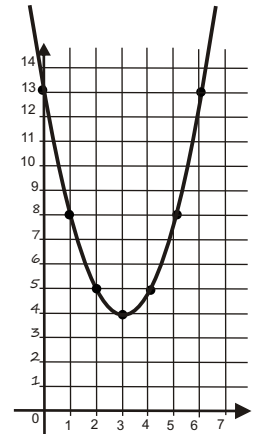

b. Write the following parabolas in the form $ax^2 + bx + c$ (where $a = 1$).

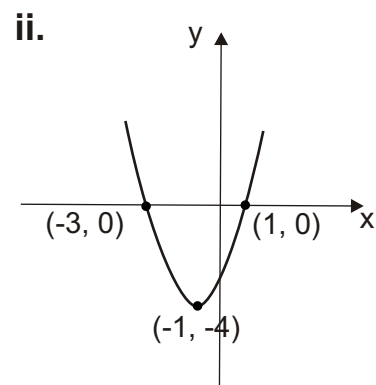
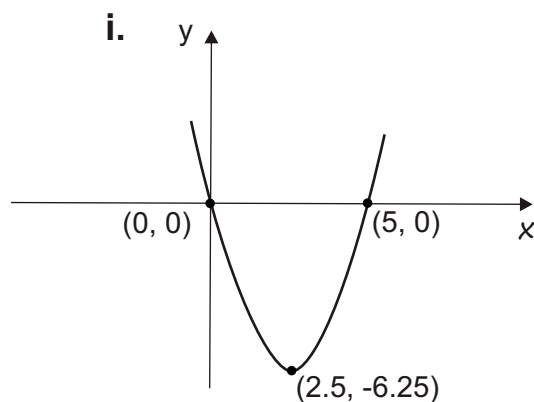

Looking at the x intercepts, equations can be easily formed.

$$y = x(x - 5)$$

$$y = x^2 - 5x$$

or using $y = a(x - h)^2 + k$ and the vertex (h, k) :

$$y = (x - 2.5)^2 - 6.25$$

$$y = x^2 - 5x + 6.25 - 6.25$$

$$y = x^2 - 5x$$

$$y = (x + 3)(x - 1)$$

$$y = x^2 + 2x - 3$$

$$y = (x + 1)^2 - 4$$

$$y = x^2 + 2x + 1 - 4$$

$$y = x^2 + 2x - 3$$

- c. Find the equation of the following parabola:

Using $y = a(x - h)^2 + k$

$$y = a(x - 1)^2 + 18$$

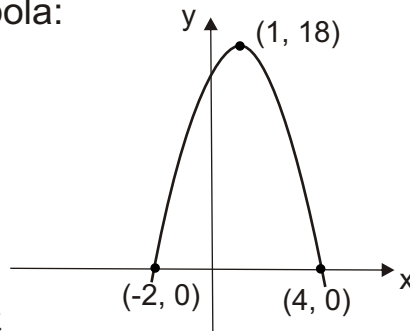

To find the value of a , substitute a Known value e.g. (4, 0)

$$0 = a(4 - 1)^2 + 18$$

$$0 = a(3)^2 + 18$$

$$0 = 9a + 18$$

$$\therefore a = -2$$

$$y = -2(x - 1)^2 + 18$$

$$y = -2(x^2 - 2x + 1) + 18$$

$$y = -2x^2 + 4x - 2 + 18$$

$$y = -2x^2 + 4x + 16$$

- d. Find the equation of the following parabola:

Using $y = a(x - h)^2 + k$

$$y = a(x - 13)^2 + 4.5$$

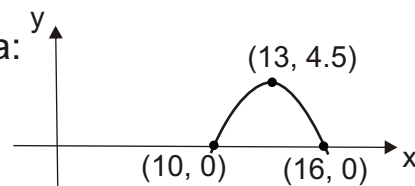

Substituting one of the known values e.g. (10, 0)

$$0 = a(10 - 13)^2 + 4.5$$

$$0 = a(-3)^2 + 4.5$$

$$0 = 9a + 4.5$$

$$a = -\frac{1}{2}$$

Going back to the original vertex form

$$y = -\frac{1}{2}(x - 13)^2 + 4.5$$

$$y = -\frac{1}{2}(x^2 - 26x + 169) + 4.5$$

$$y = -\frac{1}{2}x^2 + 13x - 84.5 + 4.5$$

$$y = -\frac{1}{2}x^2 + 13x - 80$$

Quadratic Graphs - Excellence Example

Reece and Gyn are playing volleyball. Reece is 4.0 metres from the net on one side and Gyn is 2.0 metres from the net on the other side. Reece serves the ball and it travels the path of a parabola across the court. The height of the ball as it is initially being served by Reece is 1.5 metres above the ground. The ball reaches a maximum height of 3.5 m when it is directly above the volleyball net. Gyn is able to jump and reach a height of 2.7 m. A diagram of the situation is detailed below. The diagram is not drawn to scale.

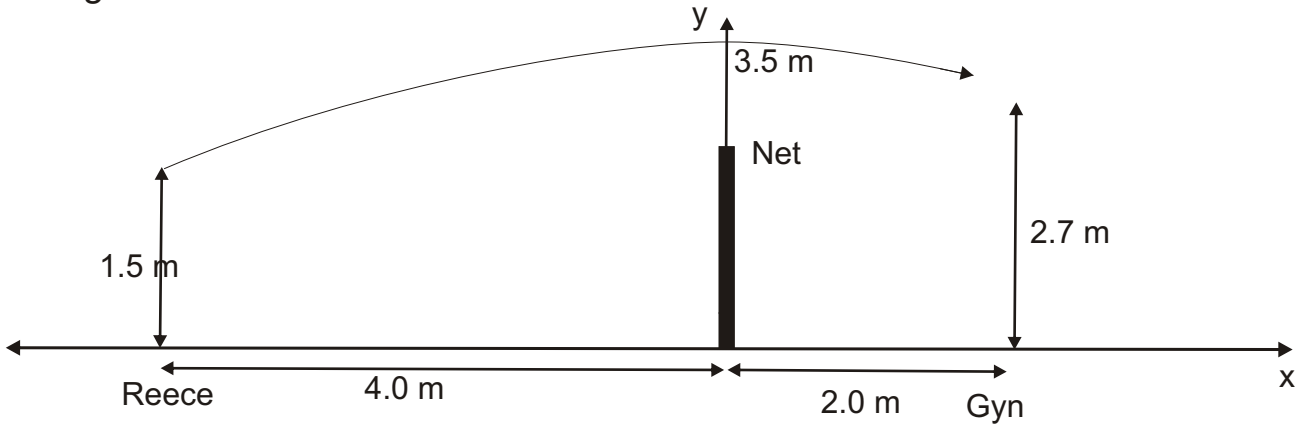

- a. Form an equation that gives the path of the ball and use the equation to determine whether Gyn can reach it or not. Justify your answer with clear mathematical reasoning.

The parabola is a  shape so it must be of the form $y = -ax^2$
 The ball rises 3.5m above the ground therefore the equation would be of the form $y = -ax^2 + 3.5$. Using the point $(-4, 1.5)$

i.e. the point at which the ball is served. $1.5 = -a(-4)^2 + 3.5$

$$1.5 = -a(16) + 3.5$$

$$-2 = -16a$$

$$a = \frac{1}{8}$$

Now that we have the equation i.e. $y = -\frac{1}{8}x^2 + 3.5$, find the height of the ball at $x = 2.0\text{m}$

$$y = -\frac{1}{8}(2)^2 + 3.5$$

$$y = -\frac{1}{8}(4) + 3.5$$

$$y = 3.0 \text{ m}$$

This means that the ball would be 3.0 m high and therefore Gyn would not be able to reach it as he can only jump and reach 2.7m.



Quadratic Graphs - Excellence Example

Beatrice is entered in the discus throwing event. One day at training she has a warm-up throw in which her coach videos her technique. The discus is 2 metres above the ground when it is released. During the first 10 seconds the height of the discus increases at a constant rate of 3 metres per second. After 10 seconds the flight of the discus can be modelled by a parabola. At 12 seconds the discus reaches a maximum height of 36 metres. The flight of the discus is graphed below.

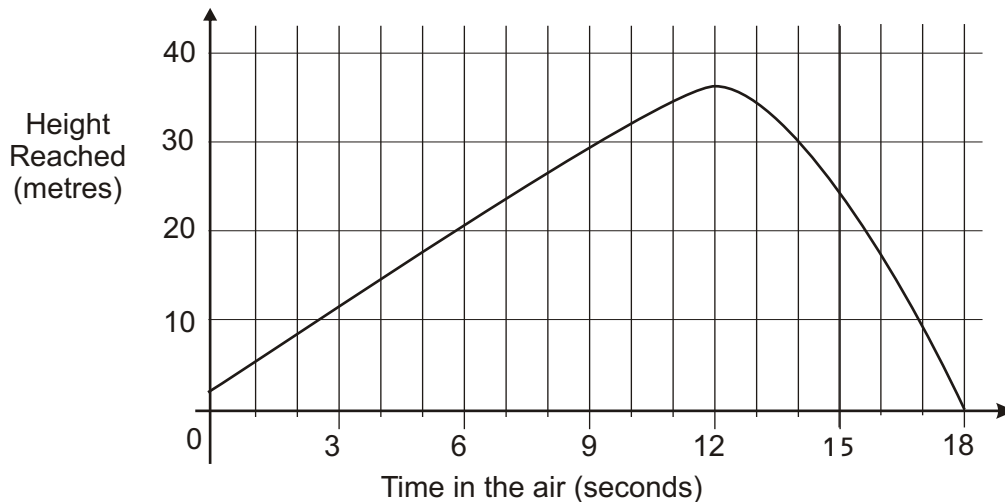

- a. Write two equations that model the flight of the discus.
The first equation is when the discus is at a constant upwards speed of 3 m/s. It is released at 2.0 metres above the ground. Therefore $H = 3t + 2$. The second equation is the parabola. The vertex of the parabola is (12, 36). Therefore the equation is $H = -(t - 12)^2 + 36$

- b. The video camera is placed 27 metres above the ground. Calculate the times when the discus is level with the video camera.

Using equation 1 $H = 3t + 2$

$27 = 3t + 2$, Therefore $t = 8.33$ seconds

Using equation 2 $H = -(t - 12)^2 + 36$

$27 = -(t - 12)^2 + 36$

$t = 15$ or 9 seconds

Therefore $t = 15$ seconds as during the first 10 seconds the discus is following the path of the other equation.

10. The jet of water from a park's water sprinkler follows the path modelled by $y = 0.5x - 0.01x^2$, where x is the horizontal distance travelled and y is vertical height that the water reaches.

a. On the grid below show the parabola $y = 0.5x - 0.01x^2$.

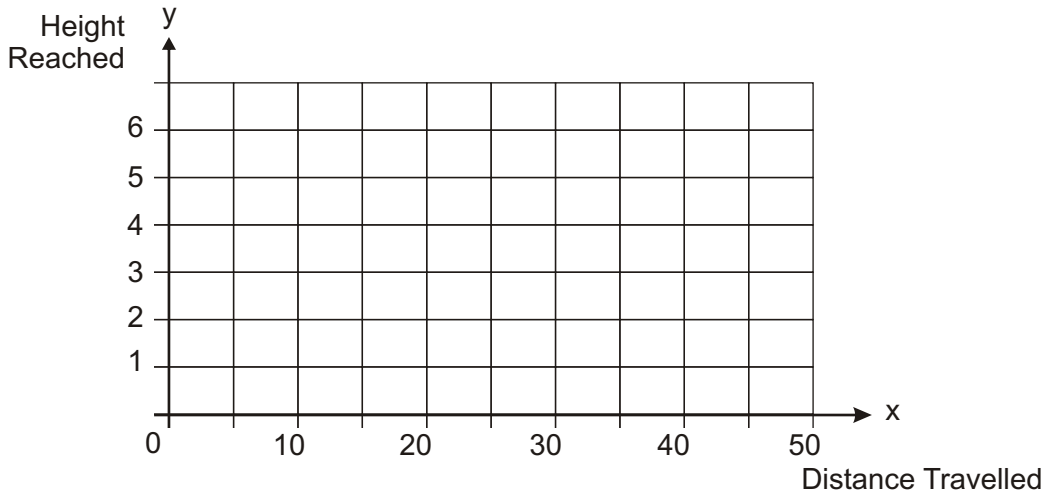

b. What is the furthest distance that the water travels?

.....

c. The midway point along the total distance travelled is also the highest point of the water jet's path. Find the greatest height that the water reaches.

.....

.....



- d. At one end of the park is a 2.25 m high fence. The water is just managing to go over the fence. Substitute $y = 2.25$ into the water equation and show that it can be rearranged as: $x^2 - 50x + 225$. Then calculate the distance of the wall from the sprinkler.

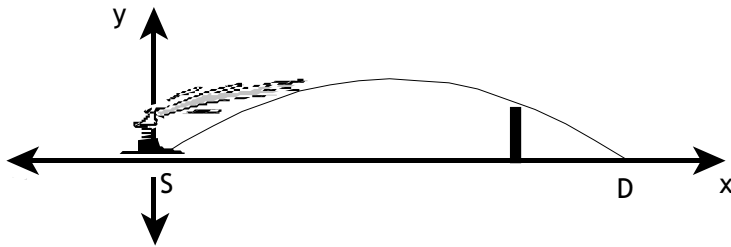

.....

.....

.....

.....

.....

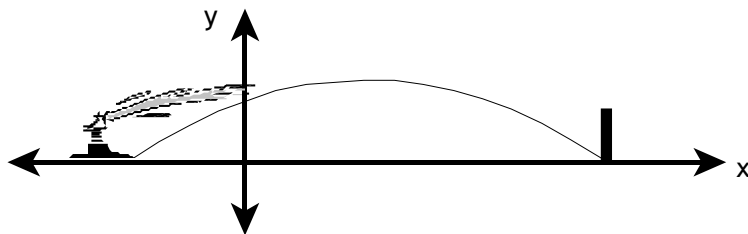

- e. If the park caretaker moves the sprinkler so that the water just reaches the base of the fence, how far will the sprinkler have to be moved?

.....

.....

.....





Level 1 Mathematics - Sample Exam

AS90148 Sketch and Interpret Graphs

*Published by Mahobe Resources (NZ) Ltd
Distributed free at www.mathscentre.co.nz*



YOU BEAUTY

Blast away blackheads

Go to school with an excellence in skin appearance!

The Environ skin care range is made from quality ingredients and is vitamin enhanced. It is free from preservatives, colourants and animal extracts. It offers a definitive regime to nourish, protect and maintain natural and beautiful skin.

Purchase Environ online at:

www.youbeauty.co.nz



CLEANSING GEL 100ml A mild foaming face and body wash, particularly recommended for oily and problematic skin.

ALPHA TONER 100ml an essential step in promoting the natural acid mantle of the skin. It removes residual cleanser and helps to firm and refine the appearance of the skin.



www.youbeauty.co.nz

You are advised to spend 25 minutes answering the questions in this section.

QUESTION ONE

Tayla and Naomi travel separately from Mathemahoe to Graftown.

Graftown is 240 km from Mathemahoe. The graph below shows their distances from Graftown in kilometres, D , and the time, t , in hours.

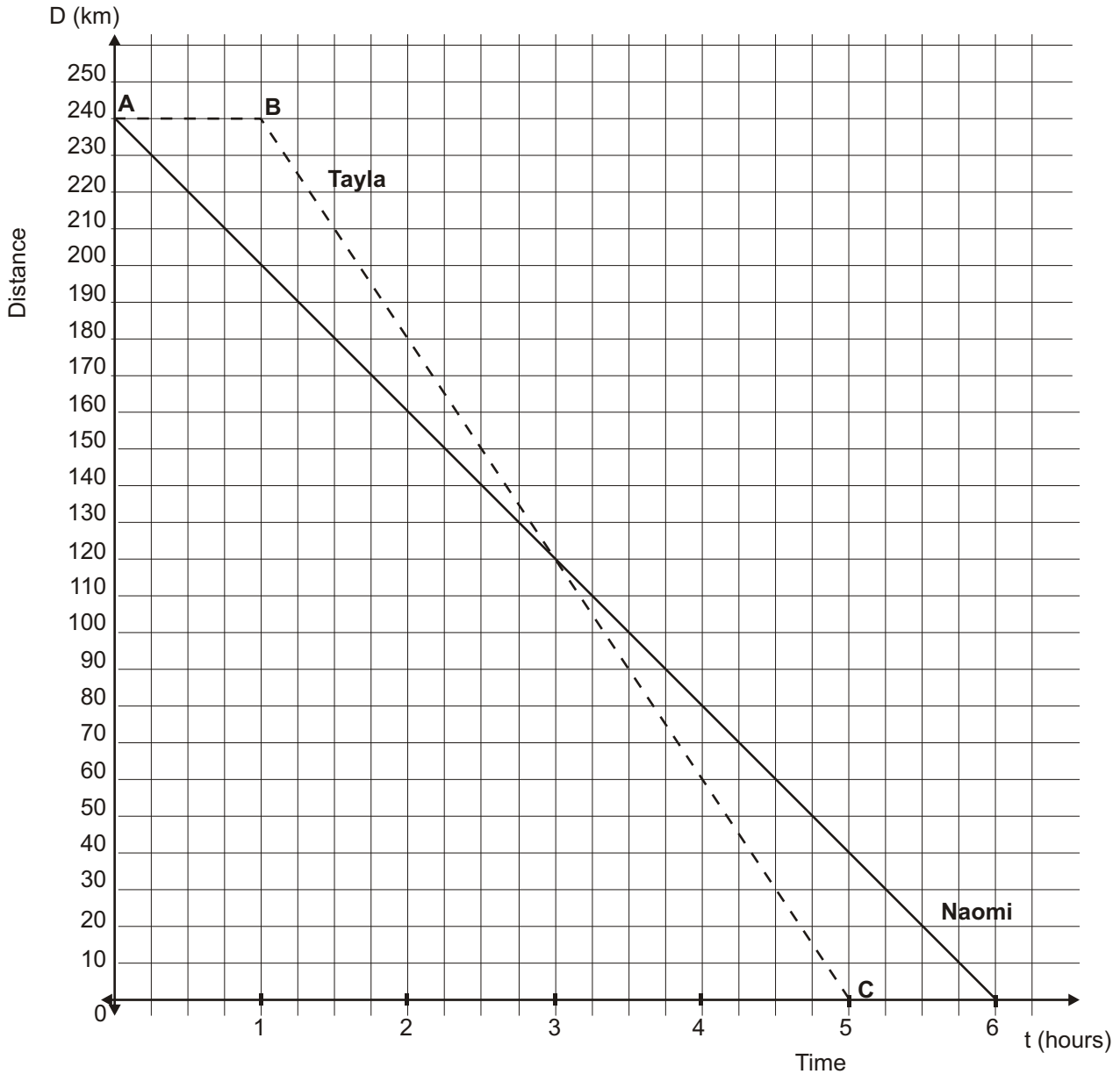

(a) What is Naomi's average speed?

- (b) Naomi has been travelling for four hours.
How far is each girl from Graftown?

Naomi

Tayla

- (c) Describe Tayla’s journey in relation to Naomi’s journey.

.....

.....

.....

.....

- (d) Leezah cycles from Newmarket to Graftown.
The distance, D, from Graftown is given by the equation:

$$D = 120 - 30t \quad \text{where } t \text{ is time in hours.}$$

Draw a line on the graph (previous page) to show Leezah’s distance from Graftown.

- (e) How long does it take for Leezah to reach Graftown?

.....

- (f) Tayla’s journey is shown on the graph on the previous page. Her journey is made up of two parts. Write the equation of both parts.

Equation AB =

Equation BC =



QUESTION TWO

Use the grids alongside to draw graphs of:

(a) $y = 3x + 4$

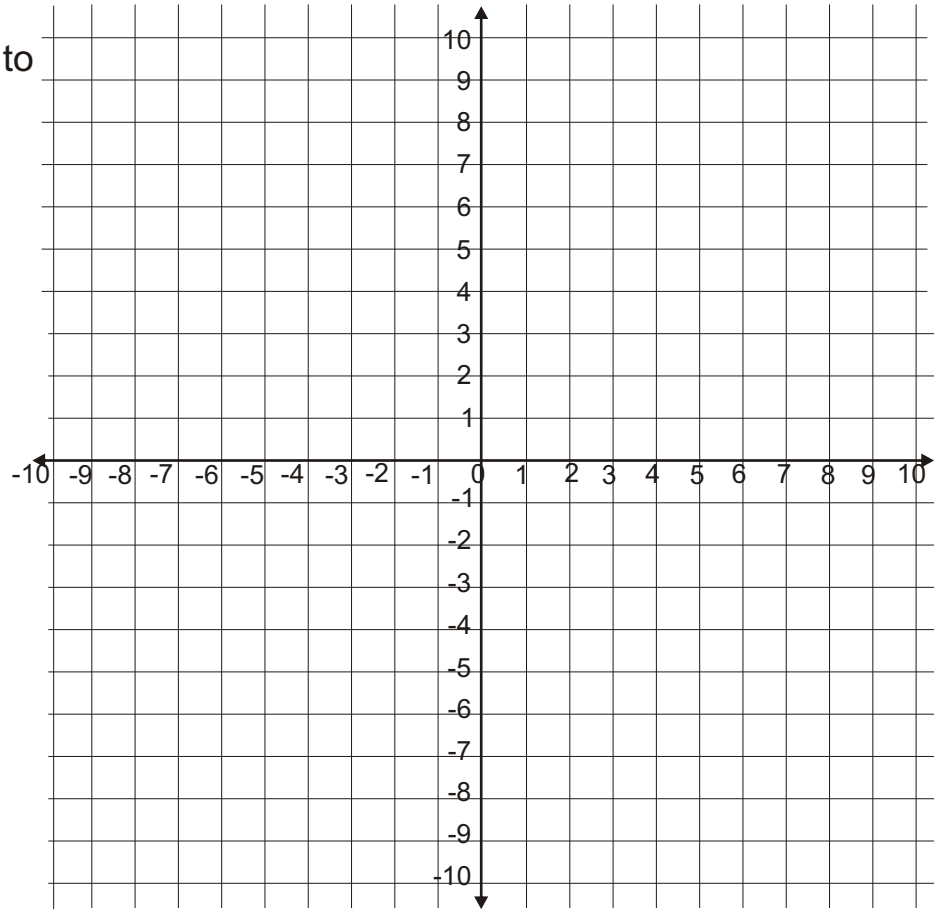

(b) $y = x^2 - 5$

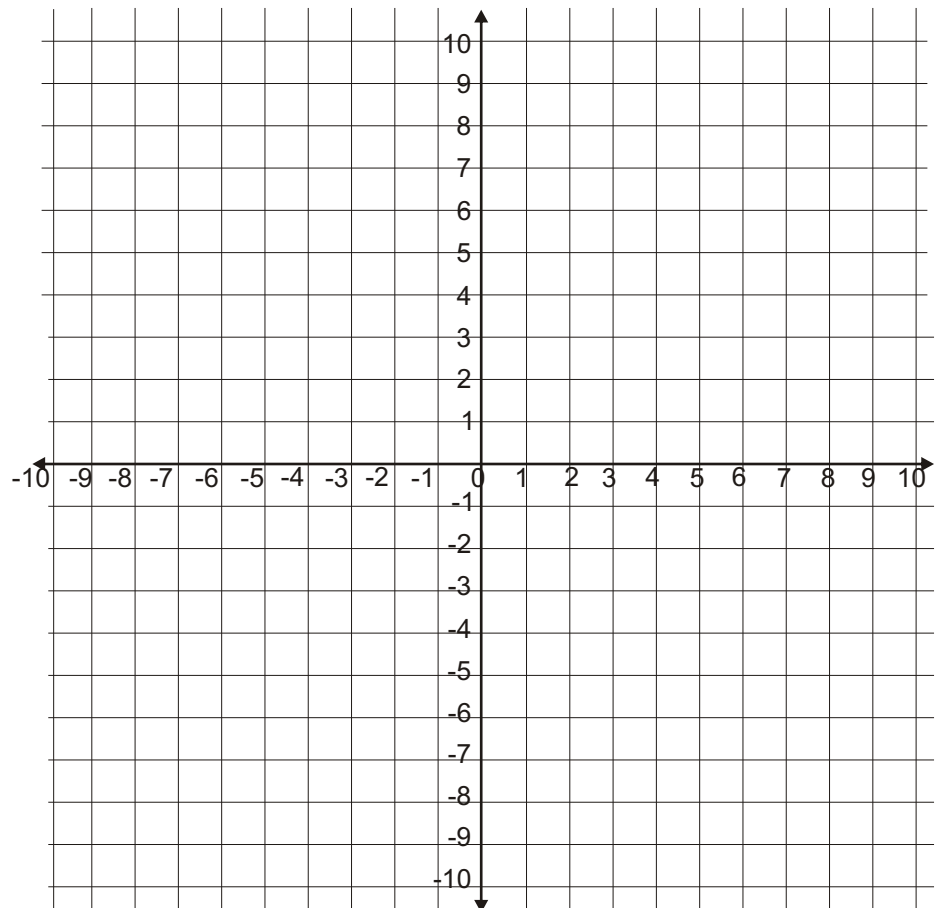

(c) $3y - 5x = 15$

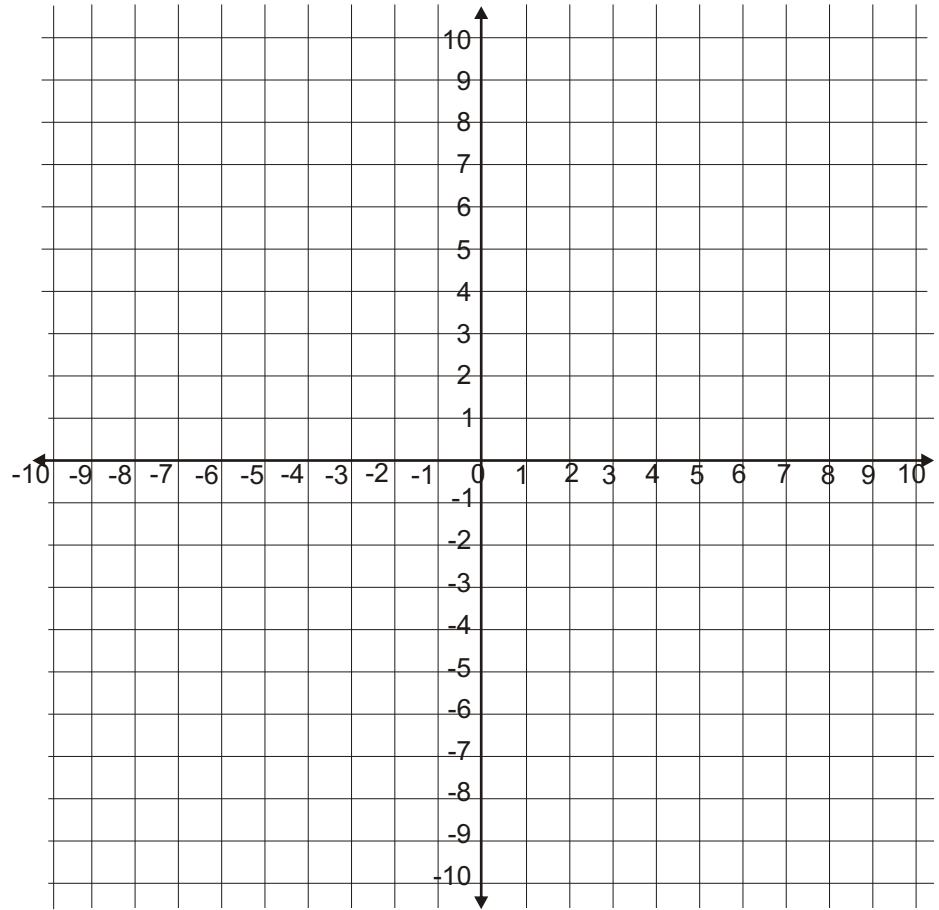

(d) $y = x(3 - x)$

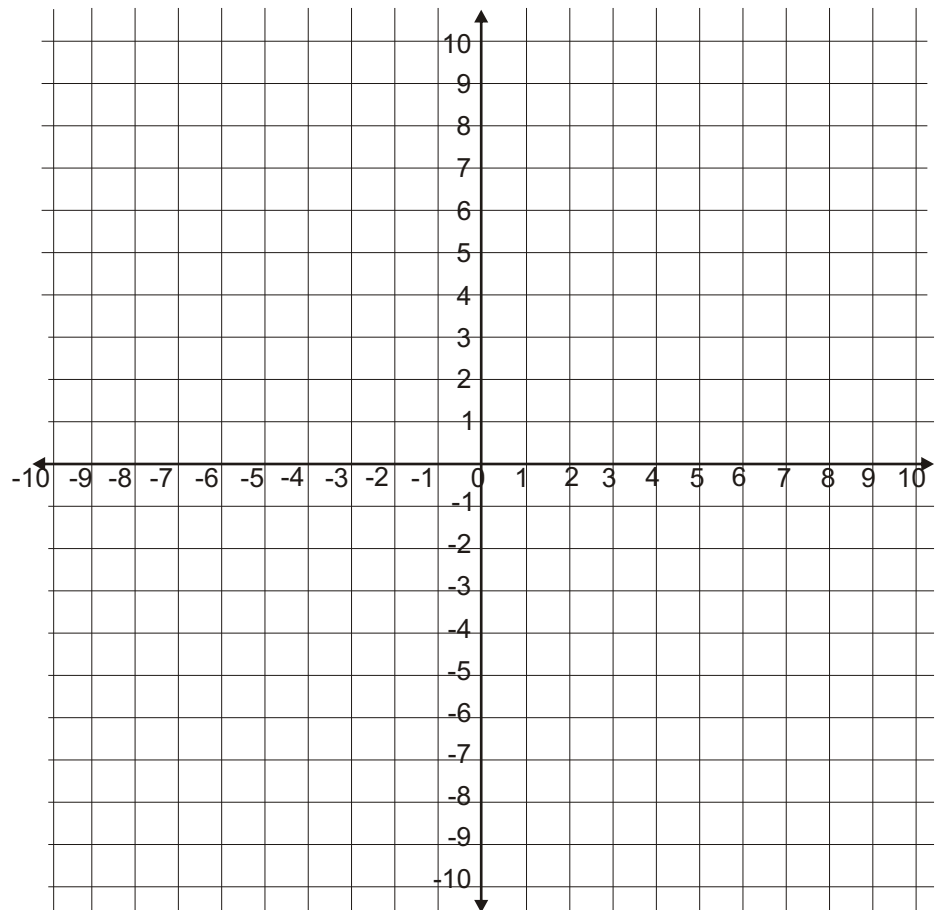

(e) $y = x^2 - 6x + 5$
 $= (x - 5)(x - 1)$
 $= (x - 3)^2 - 4$

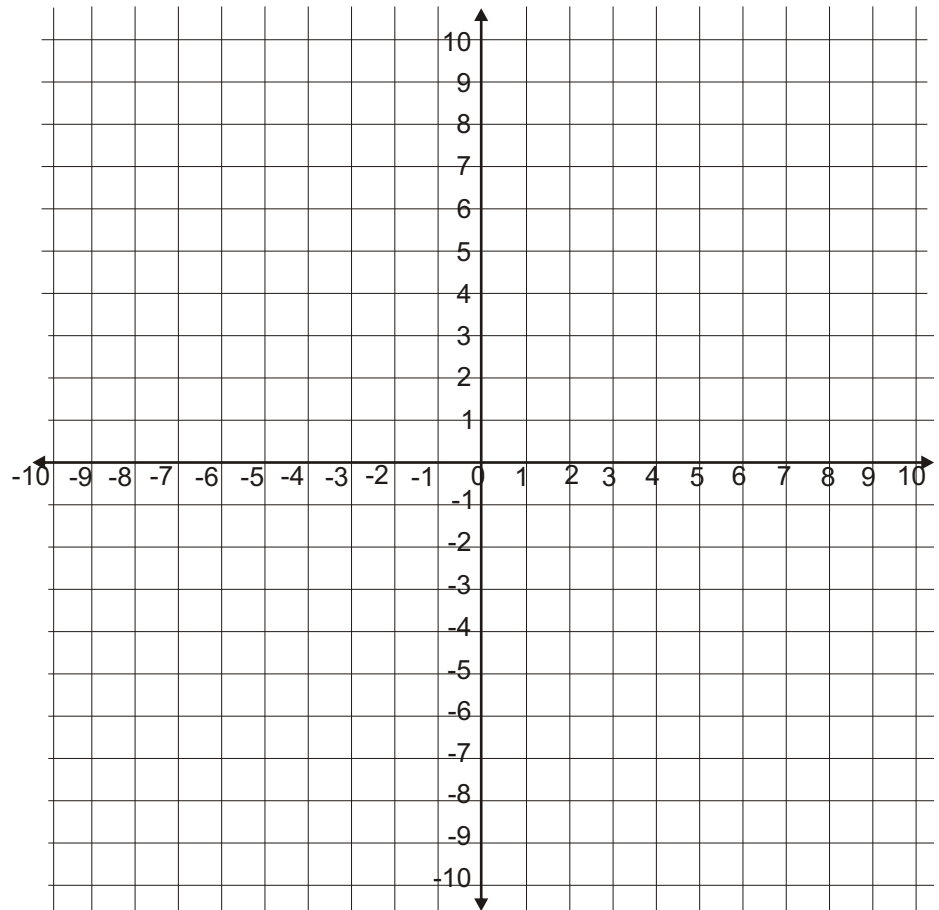

QUESTION THREE

Write the equation of the line drawn on the grid.

.....

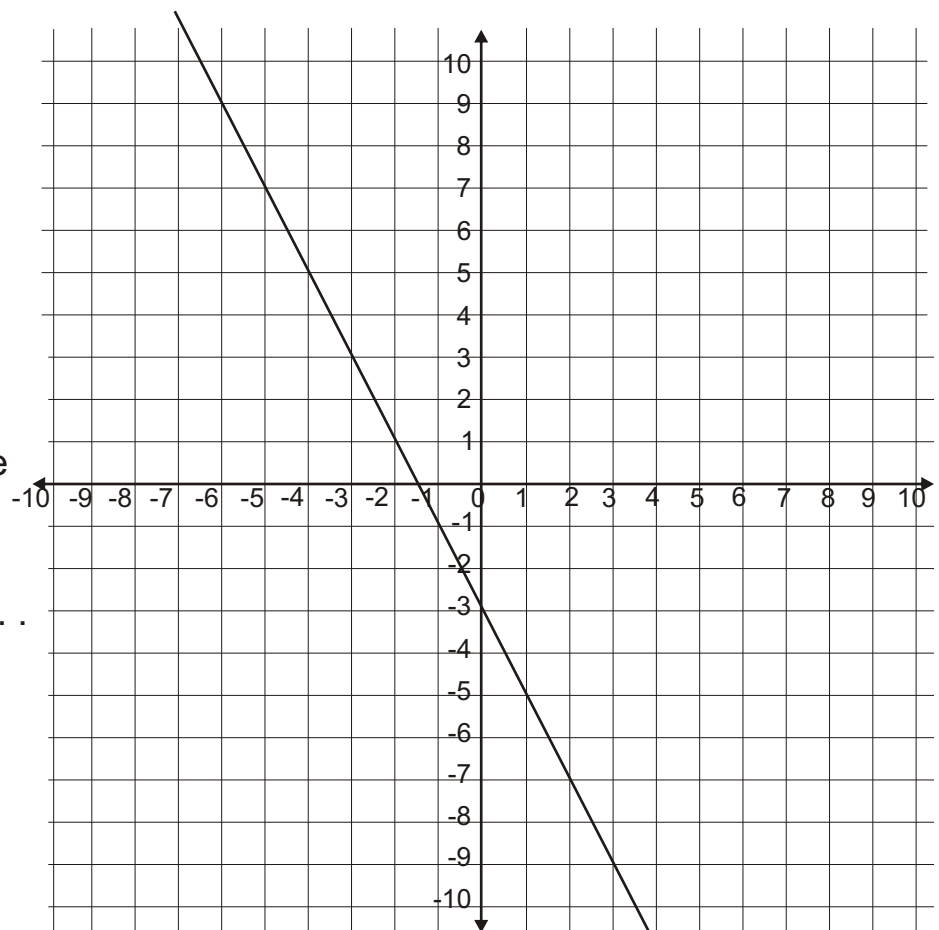

QUESTION FOUR

Bio-fuel made from recycled cooking oil is currently produced for \$2.60 per litre. Scientists predict that as their knowledge and technology improves, the cost of production will initially increase but will then decrease until the cost reaches \$0.50 per litre. The model for the production cost of one litre of bio-fuel from recycled cooking oil over the next seven years has the formula:

$$C = \frac{-1}{10} (t - 2)^2 + 3$$

The graph of the model is sketched below.

C is the production cost per litre in dollars and t is the time from now, in years.

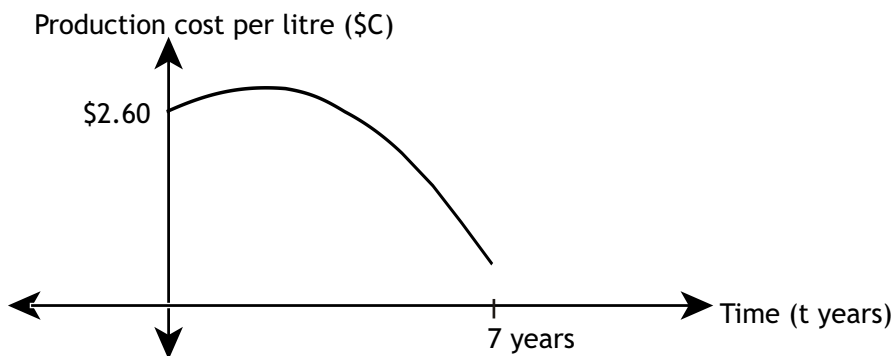

- (a) Using the model, calculate how many years it will take for production to start decreasing.

.....

.....

.....

.....

- (b) What is the maximum production cost of bio-fuel that the model predicts?

.....

- (c) How long does the model suggest it would take for production costs to be less than \$1 per litre?

.....



QUESTION FIVE

A hybrid car is fueled by a combination of battery and petrol power.

It is predicted that the number of taxis that are **not** hybrid will decrease for the next 4 years at which point all taxis will be hybrid.

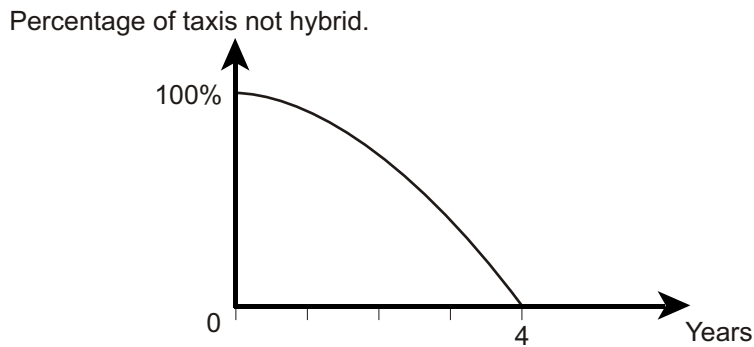

In a survey this year, no taxis were classified as hybrid. The parabola above illustrates the situation. Over the next 4 years the number of hybrid taxis will increase. Write the equation of the parabola.

Use the equation formed to calculate the number of years before 80% of taxis are hybrid.

.....

.....

.....

.....

.....

.....

.....

.....

.....

.....



The Answers



The Answers

Page 11

1. Line a equation

$$y = 3x - 5$$

Line b equation

$$y = -4x + 1$$

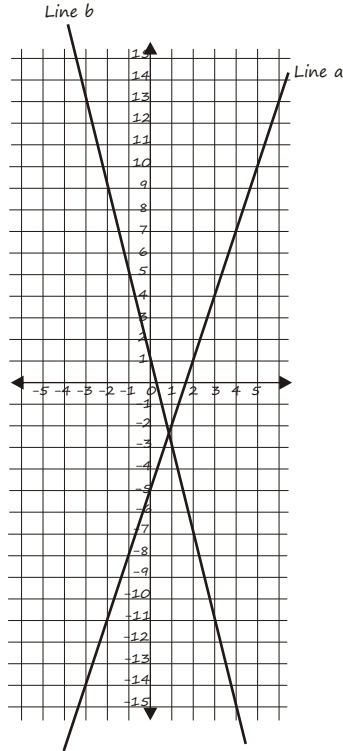

Page 13 (cont)

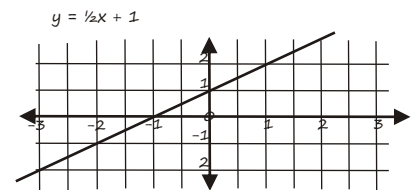
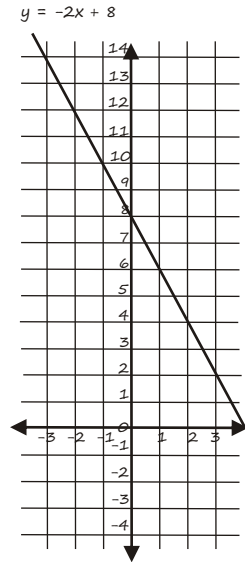
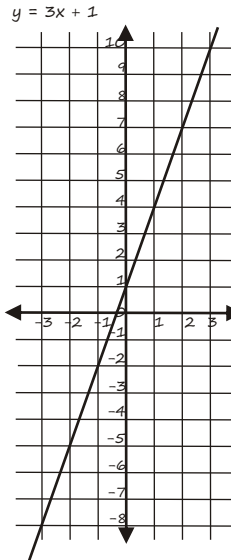

Page 12

2. a. Co-ordinates of A = (-1, 1)
Co-ordinates of B = (3, 3)
- b. x intercept = (-3, 0)
y intercept = (0, 1.5)
- c. Equation $y = 0.5x + 1.5$
3. Parallel lines = A & C (gradient = 3)
Negative gradients = B & D
Point (5, 13) = A & D
4. x values: -3, -2, -1, 0, 1, 2, 3
 - a. -10, -8, -6, -4, -2, 0, 2
 - b. -8, -5, -1, 1, 4, 7, 10
 - c. $-\frac{1}{2}$, 0, $\frac{1}{2}$, 1, $1\frac{1}{2}$, 2, $2\frac{1}{2}$
 - d. 14, 12, 10, 8, 6, 4, 2

Page 14

5.

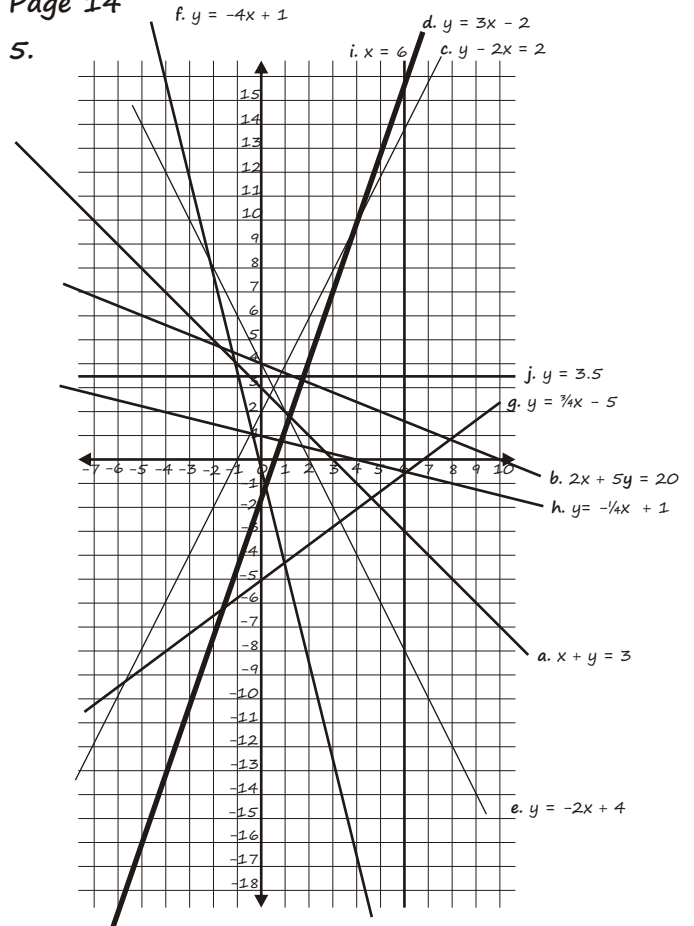

Page 13

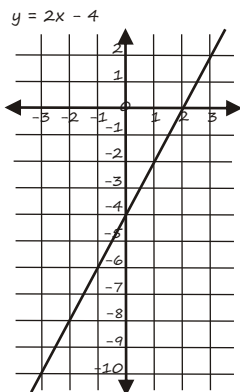

Page 15

6. a. Michael is the initially the most successful.
- b. Annual rate of change is:
Britany: $\$125 \div 8 = \$15.625m$
Paris: $\$75 \div 8 = \$9.375m$
- c. Michael's net worth is declining at a rate of \$40 million per year He will be worth less than \$1m during 2011.

Page 16

7. a. The line between 300 metres and 6 minutes is Britney. The slope of the line tells us that she ran 300 metres in 6 minutes.
The line between 200 metres and 8 minutes is Paris. The slope of the line tells us that she walked 200 metres in 8 minutes.
- b. At 4 minutes they are both 100 metres from the mall i.e. 1.34pm

Page 17

8. Cooking time (minutes)
80, 130, 180, 230, 280

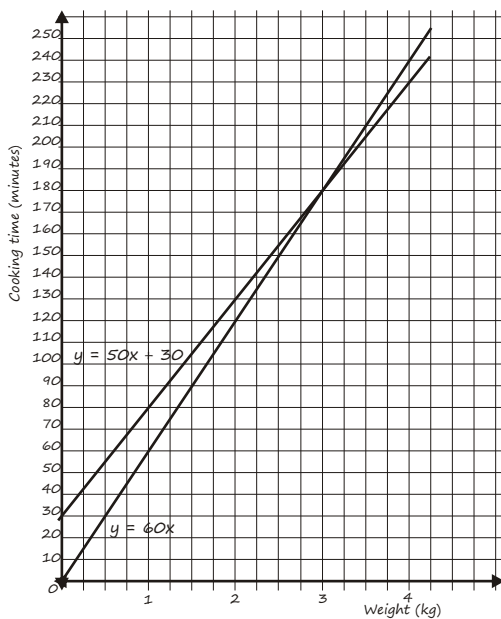

Page 17 (cont)

The two equations are:
 $y = 50x + 30$ (Ramsey's recipe book)
 $y = 60x$ (Ramsey's mum)

The first recipe cooks the roast slowly. If the first recipe is correct then the second will undercook the roast for up to 3kg and then overcook it for weights over 3kg. Both methods agree on a cooking time for a 3kg roast.

Page 18

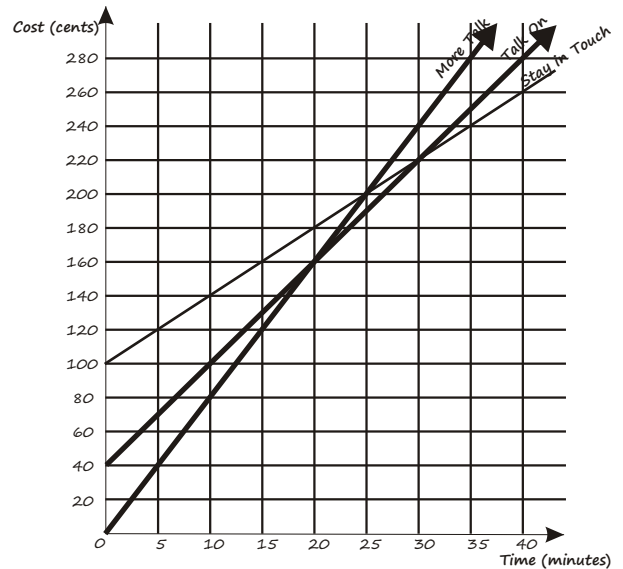

Page 19

- b. i. Stay In Touch
ii. Cost at Time = 0 is the highest
- c. i. 20 minutes
ii. The lines for both intersect
- d. i. More Talk equation: $C = 8t$
ii. Talk On equation: $C = 6t + 40$

Page 20

10. a. Work it Out has fixed a daily rate while Fitness Concepts has a an initial fixed fee with a daily rate. If hiring equipment for less than 40 days it would be better to use Work it Out. After 40 days you would be better with Fitness Concepts.



Page 20 (cont)

- b. After 20 days you are charged \$60. Therefore the daily rate is \$3 per day.
- c. The fixed fee is \$100
- d. Fitness Concepts would charge \$118 (\$100 + \$0.40 per day)
Work it Out would charge \$135 (45 × \$3)
The cheaper option is Fitness Concepts. If Terrence was to continue hiring the equipment he would save even more.

Page 25

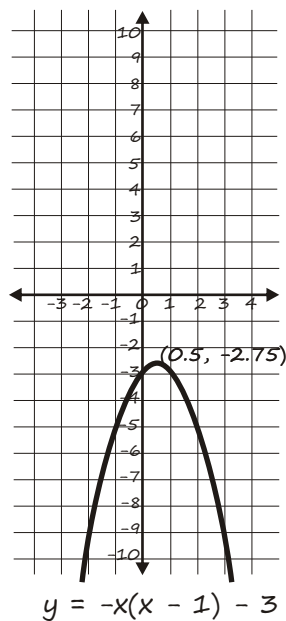
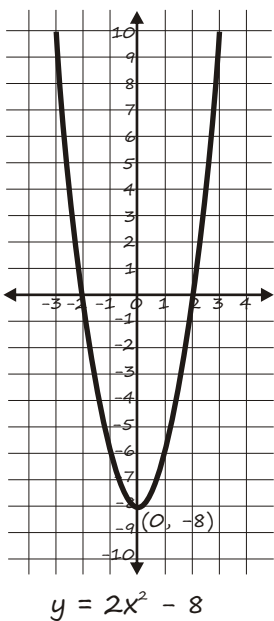
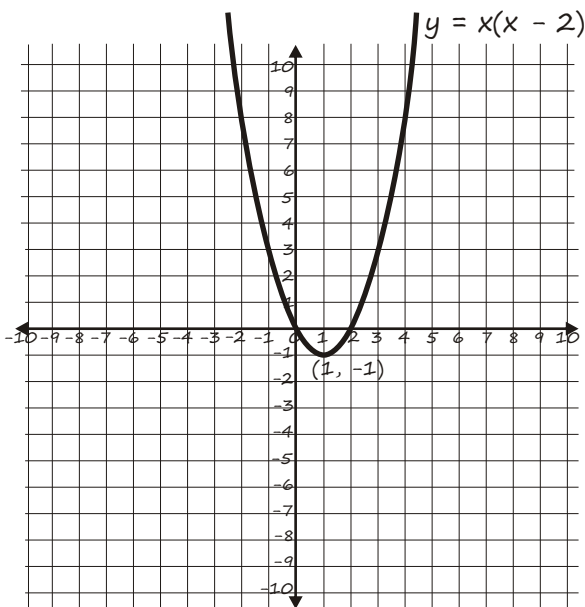

Page 26

d.

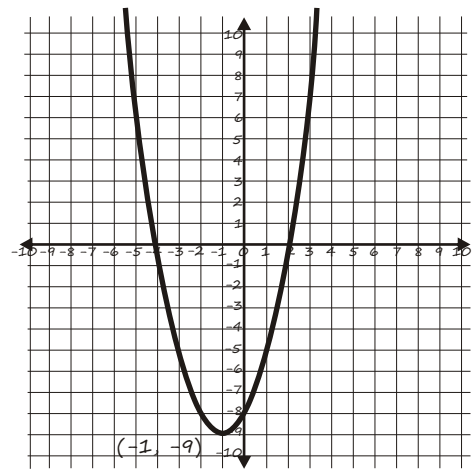

$y = (x - 2)(x + 4)$

e.

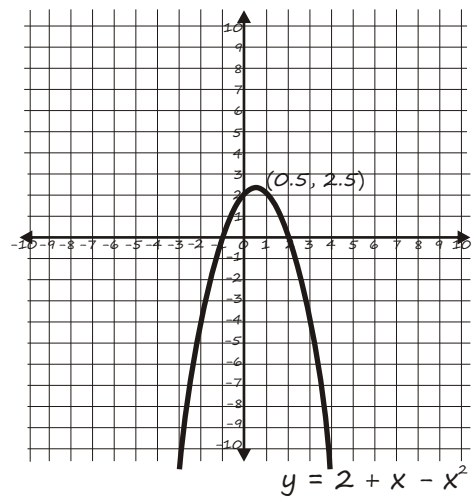

Page 27

- 2 a. $y = x^2 - 7x + 6$
y intercept is when $x = 0$
y intercept = $(0, 6)$
x intercept is when $y = 0$
 $x^2 - 7x + 6 = 0$
 $(x - 6)(x - 1) = 0$
 $x = 6$ or $x = 1$

The x co-ordinate of the vertex is half way between the x intercepts. With this equation the vertex x value is 3.5

$y = (3.5)^2 - 7(3.5) + 6$
 $y = -6.25$

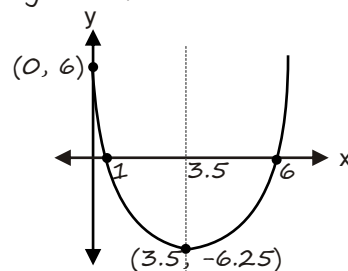

Page 27 (cont)

b. $y = x^2 + 8x - 20$
 y intercept is when $x = 0$
 y intercept = $(0, -20)$
 x intercept is when $y = 0$
 $x^2 + 8x - 20 = 0$
 $(x + 10)(x - 2) = 0$
 $x = -10$ or $x = 2$

The x co-ordinate of the vertex is halfway between the x intercepts.
 With this equation the vertex x value is -4

$$y = (-4)^2 + 8(-4) - 20$$

$$y = -36$$

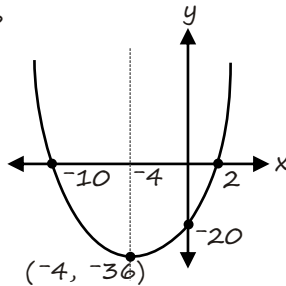

c. $y = x^2 - 2x - 35$
 y intercept is when $x = 0$
 y intercept = $(0, -35)$
 x intercept is when $y = 0$
 $x^2 - 2x - 35 = 0$
 $(x - 7)(x + 5) = 0$
 $x = 7$ or $x = -5$

The x co-ordinate of the vertex is halfway between the x intercepts. With this equation the vertex x value is 1

$$y = (1)^2 - 2(1) - 35$$

$$y = -36$$

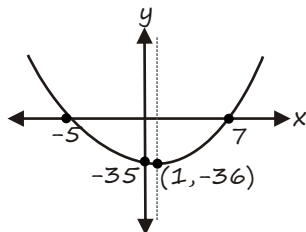

Page 27 (cont)

d. $y = x^2 - 3x$
 y intercept is when $x = 0$
 y intercept = $(0, 0)$
 x intercept is when $y = 0$
 $x^2 - 3x = 0$
 $x(x - 3) = 0$
 $x = 0$ or $x = 3$

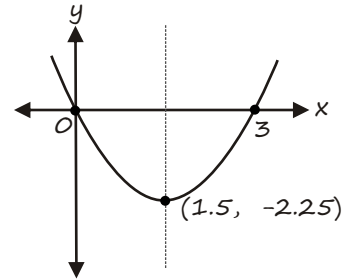

3. $y = (x - 2)(x + 3)$
 A = y intercept when $x = 0$
 $y = (0 - 2)(0 + 3)$
 $y = -6$
 A = $(0, -6)$

B and C = x intercepts when $y = 0$

$$(x - 2)(x + 3) = 0$$

$$x = 2 \text{ or } x = -3$$

$$B = (-3, 0)$$

$$C = (2, 0)$$

D is halfway between the x intercepts

$$D = (-0.5, 0)$$

E is the vertex when $x = -1.5$

$$(-0.5 - 2)(-0.5 + 3)$$

$$= -3.5 \times 1.5$$

$$= -6.25$$

$$E = (-0.5, -6.25)$$

Page 28

4. $(3 + x)$: 1, 2, 3, 4, 5, 6
 $(x - 2)$: -4, -3, -2, -1, 0, 1
 -4, -6, -6, -4, 0, 6

Page 28 (cont)

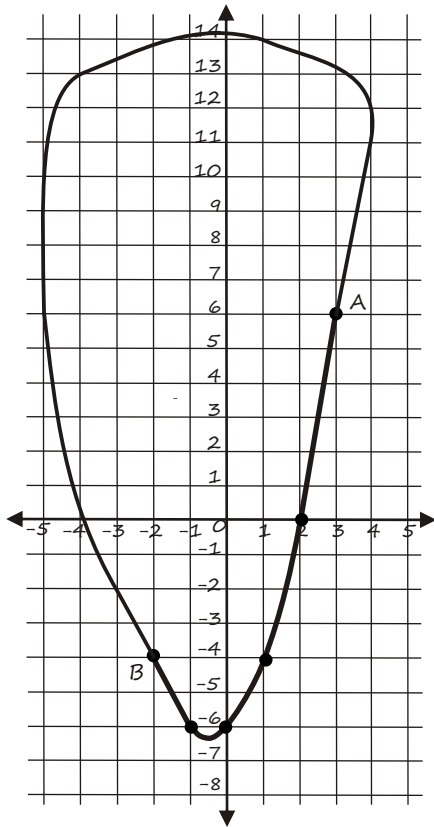

Page 32 (cont)

- f. Intersection points (see graph below) are $(-2, 0)$ and $(2, 8)$. These points can be confirmed by substitution into either equation.

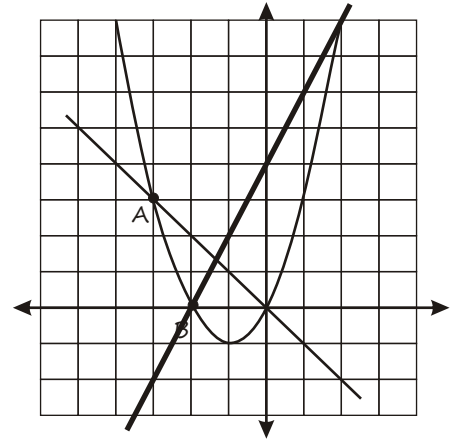

Page 33

6. a. $20 \times 40, 50, 60, 80, 100, 120$
 $-4x^2, 16, 25, 36, 64, 100, 144$
 24 25 24 16 0 -24

b.

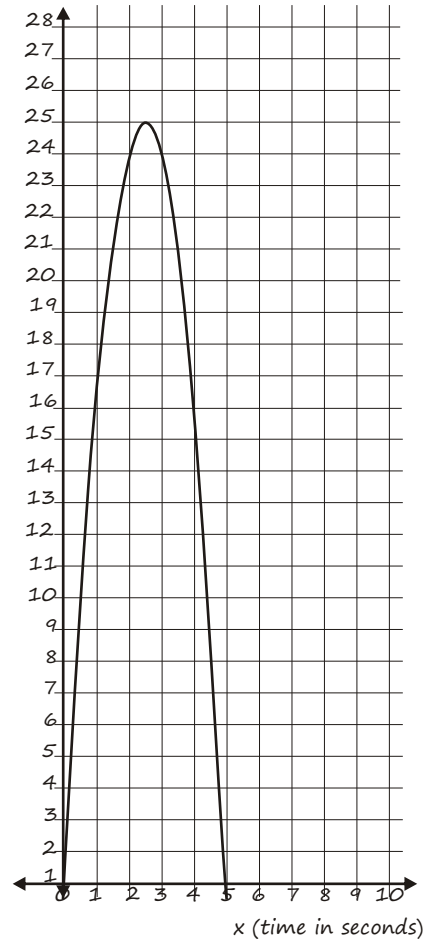

Page 32

5. a.

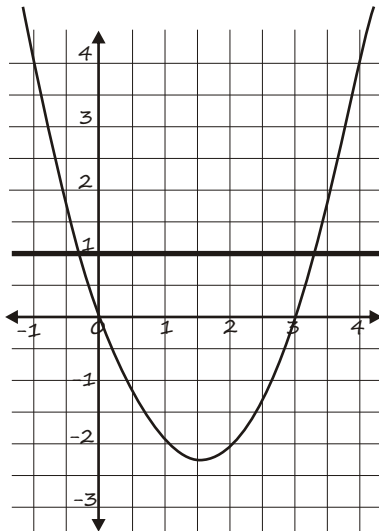

- b. There are two solutions. Actual solutions (although not asked for or required) are $X = -0.3027$ and $x = 3.3027$
- c. $A = (-3, 3), B = (-2, 0)$
- d. There are many possible answers. Your coordinate must lie on the parabola e.g. $(-1, -1)$ $(0, 0)$ or $(1, 3)$
- e. Gradient = 2

Page 33 (cont)

- c. The ball travels up into the air for 2.5 metres. This takes 2.5 seconds. It then travels back down to earth where it hits the ground at 5 seconds.
- d. In theory after 5 sec the ball is travelling underground. In reality, it would hit the ground and bounce back into the air.

Page 34

7. a. y values -4.5, -5, -4.5, -3, -0.5

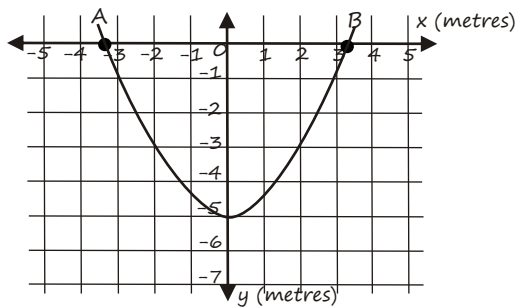

- c. $x^2 - 10 = 0$
 $x^2 = 10$, $x = \pm 3.162$
 This means total width
 $6 \times 3.162 = 18.97$

Page 35

8. Find the distance along the x axis when the height of the tunnel is 7m.
 $x^2 = -4(7 - 9)$
 $x^2 = 8$, i.e. $x = 2.828$
 The truck is 4m wide. Therefore it could not travel down one half of the road.

However, maybe it could travel along the middle of the road to safely go through the tunnel. At the top of the next column is the calculation for the clearance between the top of the truck and the tunnel when traveling down the middle of the road. When in the middle of the road the truck is 2m either side of the y axis.

Page 35 (cont)

$$2^2 = -4(y - 9)$$

$$4 = -4y + 36$$

$$-32 = -4y$$

$$y = 8$$

Therefore there would be 1m clearance when traveling down the middle of the tunnel.

Page 36

9.

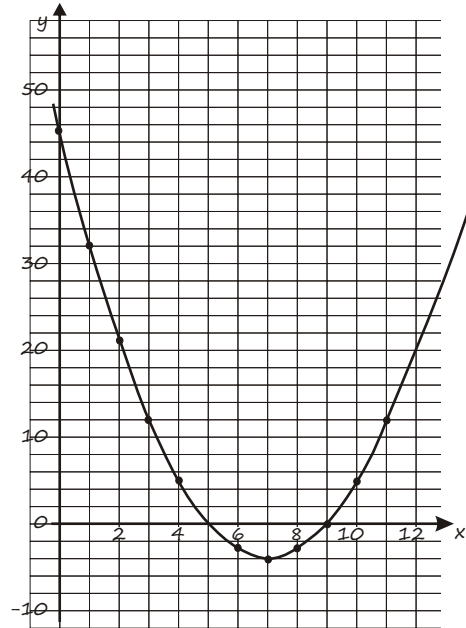

- a. Intercepts (0, 45), (5, 0), (9, 0)
 Turning point (7, -4)

Page 37

- b. The bottom of the drop occurs at $x = 7$ m
- c. Roller Coaster drops 49 m
- d. Solutions $x = 5$ and $x = 9$
- e. $y = (x - 7)^2 - 4$

Page 43

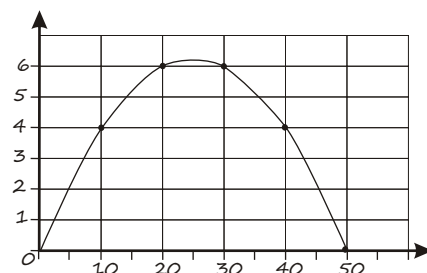

Page 43 (cont)

- b. The furthest distance = 50 m
- c. The highest point is at the midpoint of the parabola i.e. 25m
 $0.5(25) - 0.01(25)^2 = 6.25$ m

Page 44

- d. $2.25 = 0.5x - 0.01x^2$
 $0.01x^2 - 0.5x + 2.25 = 0$
 (multiply by 100)
 $x^2 - 50x + 225 = 0$
 $(x - 5)(x - 45) = 0$
 $x = 5$ or $x = 45$
 The fence is 45 m (the furthest of the two factors) from the sprinkler.
- e. The total distance from the sprinkler that the water travels is 50m. The fence is at 45 m. Therefore move the sprinkler back 5 m.

Page 48, Question One

- a. Naomi's average speed
 $240\text{km} \div 6\text{hrs} = 40$ km/hr

Page 49

- b. After 4 hours Naomi is 80 km from Graftown, Tayla is 60 km from Graftown
- c. For the first hour Tayla is driving around Mathemahoe. She then drives towards Graftown at a faster rate than Naomi (at $240\text{km} \div 4\text{hrs} = 60$ km/hr).

Page 49 (cont)

d.

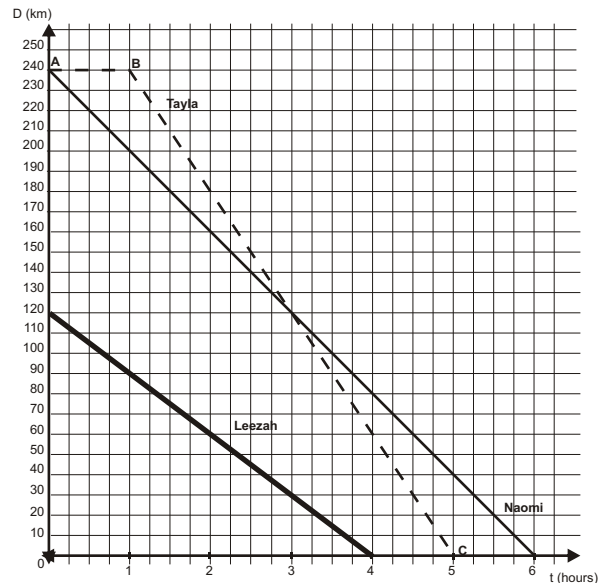

- e. 4 hours
- f. AB, $D = 240$, where $0 \leq t \leq 1$
 BC, $D = 240 - 60t$ where $1 \leq t \leq 5$

Page 50

- a. $y = 3x + 4$

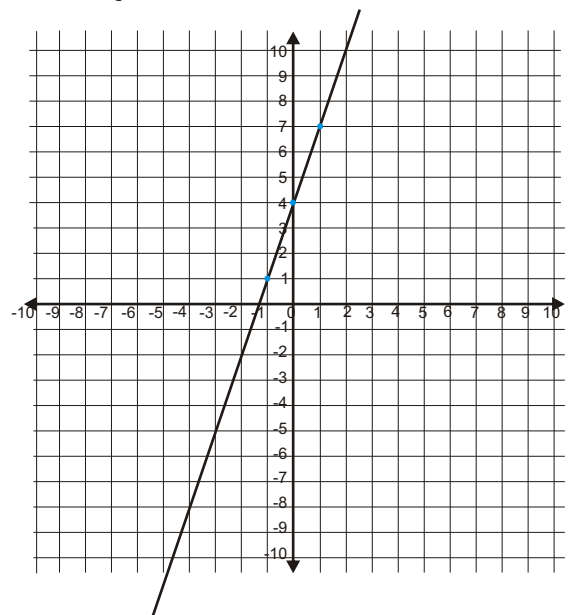

Page 50 (cont)

b. $y = x^2 - 5$

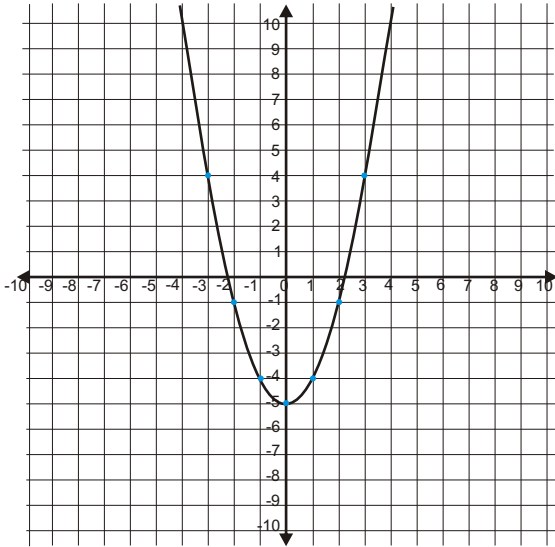

Page 51

c. $3y - 5x = 15$

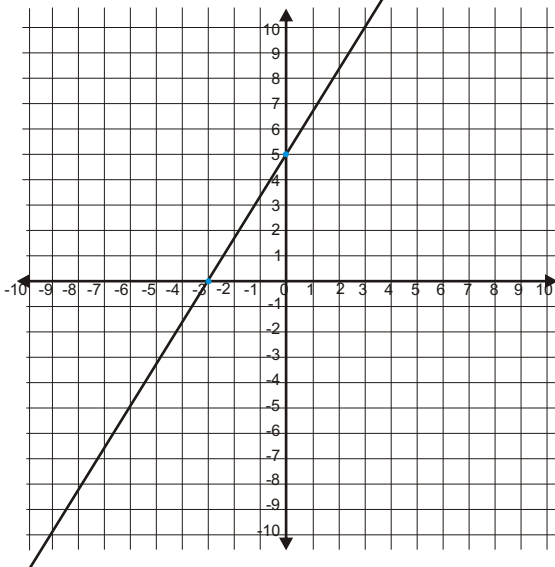

d. $y = x(3 - x)$
 Max = (1.5, 2.25),
 Intercepts (0,0), (3, 0)

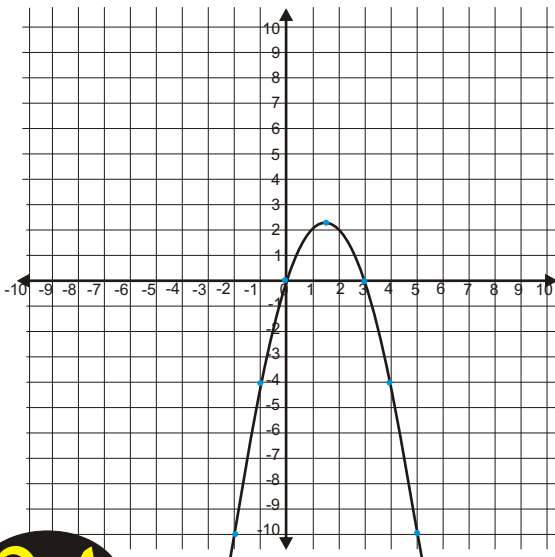

Page 52

e. $y = (x - 5)(x - 1)$
 Points of interest:
 x intercepts (1, 0)(5, 0)
 y intercept (0, 5)
 minimum (3, -4)

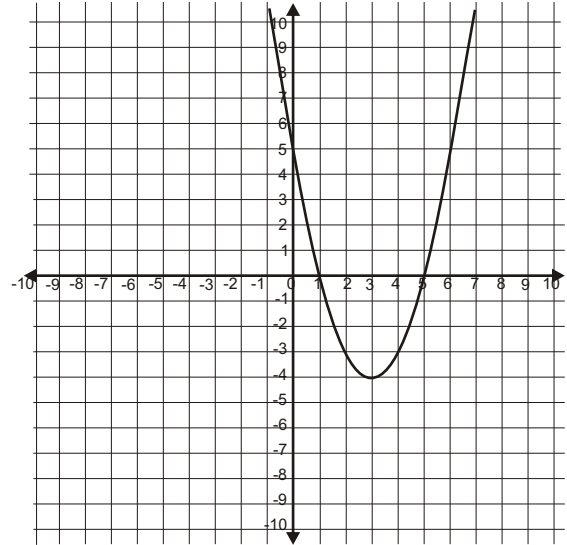

3. y intercept is -3
 gradient is -2
 equation is $y = -2x - 3$

Page 53

4. You can calculate this by drawing up a table.
 Year 0, 1, 2, 3, 4, 5, 6, 7
 Cost: 2.6, 2.9, 3, 2.9, 2.6, 2.1, 1.4, 0.5
- The table shows that production will start decreasing after 2 years.
 - The maximum production cost (at two years) will be \$3.
 - The production costs will be less than \$1 between 6 and 7 years.
- The above figures can also be calculated using $a(x - h)^2 + k$ where (h, k) is the maximum value (2, 3) i.e. 2 years, \$3

Page 54

5. 80% hybrid means 20% not hybrid.
The curve is a parabola meaning that in theory it runs from -4 to 4.

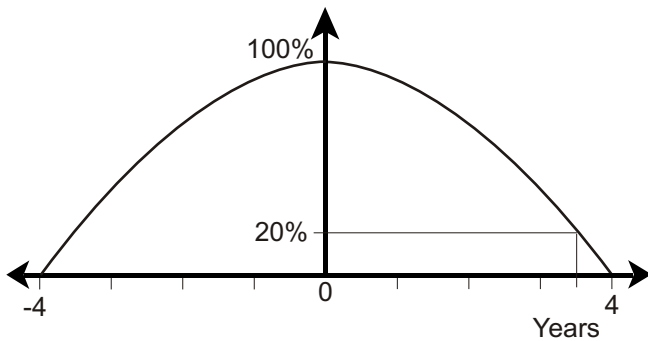

The parabola is a  shape
therefore it must be of the form $y = -ax^2$
Using the point $(0, 100)$ the equation
can be further drafted to be:

$$y = -ax^2 + 100$$

Using the point $(4, 0)$

$$0 = -a(4)^2 + 100$$

$$0 = -16a + 100$$

$$a = 6.25$$

This means the equation is:

$$y = -6.25x^2 + 100$$

This means at $y = 20$

$$20 = -6.25x^2 + 100$$

$$-80 \div -6.25 = x^2$$

$$12.8 = x^2$$

$$x = 3.58 \text{ years}$$

At this time, 80% of the taxis will be hybrid.



The Mahobe RedBack Calculator

The NZ Centre of Mathematics recommends the Mahobe RedBack scientific calculator for NCEA. This calculator has advanced features, such as equation solving, to help take the sweat out of such calculations. Purchase it direct from the Mahobe website www.mahobe.co.nz.



NCEA Level 1 English Questions & Answers

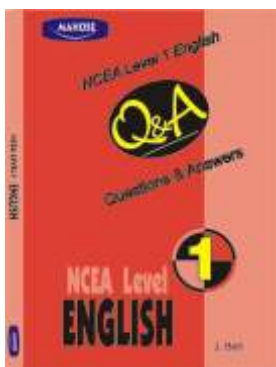

Each of the English Achievement Standards are introduced with a wide range of writing topics along with excellent hints on how to structure and write an outstanding essay. There are many sample excellence essays from previous years' successful students. This book shows you how to combine all your teacher and class notes and practise successfully for each assessment. Q&A English is \$14.95 and can be purchased from Whitcoulls, Paper Plus or from the Mahobe website www.mahobe.co.nz

NCEA Level 1 Science Questions & Answers

There are explanations and practice NCEA assessments of the type that can be expected in the exam. This book allows you to focus on the exam essentials. It will your boost confidence and maintain motivation in the weeks leading up to the exams. Study with this book and you will enter the exam room with more comfort, confidence and enthusiasm. Q&A Science is \$19.95 and can be purchased from Whitcoulls, Paper Plus or from the Mahobe website www.mahobe.co.nz

